



More Precision

thermoIMAGER TIM // Compact thermal imaging cameras





- Temperature range from -20 °C to 2000 °C
- Compact cameras ideal for OEM applications
- Up to 1 kHz for fast processes
- Resolution up to 764 x 480 pixels
- License-free analysis software and complete SDK included

thermoIMAGER TIM - compact USB thermal imaging cameras for precise thermography

Non-contact measurements of temperature distribution using thermal imaging cameras enable to efficiently monitor and control temperature-critical processes in various fields of application. The thermoIMAGER infrared cameras are renowned for stationary thermography providing an excellent price/performance ratio. The thermal imaging cameras are connected via USB 2.0 to a computer and are promptly ready for use. The license-free TIMConnect software visualizes and records the detected temperature data as thermal images. Additionally, the software provides set up and configuration and enables to control the infrared cameras.

Functioning principle of Micro-Epsilon thermal imaging cameras

Thermal imaging cameras from Micro-Epsilon are designed to measure surface temperatures from -20 °C to 2000 °C. The infrared radiation emitted by a body is used for the measurement. As this measurement is a non-contact technology, the devices perform wear-free and can therefore be reliably used in the long term. Selectable models and optical systems enable to install the cameras in different distances from the surface. This enables measurements to the target from a safe distance in critical operation areas.

Page	Model	Description
4 - 5	TIM 160	Miniaturized thermal imaging camera with USB interface
6 - 7	TIM 200 / 230	Thermal imager with BI-SPECTRAL technology
8 - 9	TIM 400 / 450	Thermal imaging camera with high resolution and sensitivity
10 - 11	TIM 640	Worldwide smallest VGA thermal imaging camera
12 - 13	TIM G7 / G7 VGA	Thermal imaging camera with line scan feature for the glass industry
14 - 15	TIM M1	Thermal imaging camera for hot metal surfaces
16 - 17	TIM M1 Special models / Protection housings	Thermal imaging cameras with blocking filter and cooling enclosure for hot metal surfaces
18 - 19	TIM M05	Thermal imaging camera for molten metal and metal surfaces
20 - 21	USB Server Gigabit / Process interface	Simple cable extension and industrial process interface
22 - 23	TIM NetPC / NetBox	PC solution for applications and miniature PC
24 - 25	Software features / Lenses	TIMConnect software / Suitable lenses for every application
26 - 27	Lenses	Suitable lenses for every application

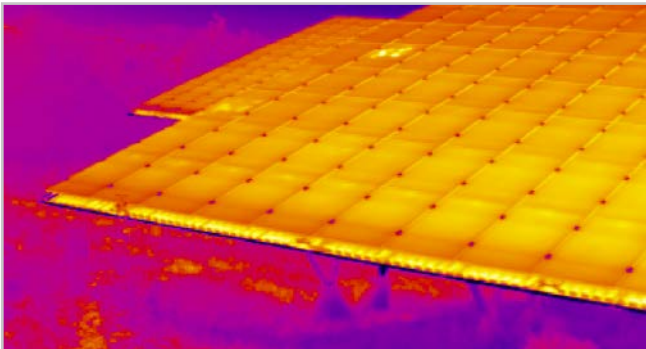

Fast temperature measurement even on large surfaces

Due to this non-contact technology, measurement objects can be detected precisely and wear-free. Large surfaces can be measured accurately at millisecond intervals. The camera can be operated in the line monitoring mode in order to continuously monitor the process.



Compact design for mobile and stationary use

The thermolMAGER cameras close the previous gap between portable infrared snapshot cameras and devices for stationary use.

Exemplary fields of applications:

- Process automation
- Test stations
- Research & Development
- Mobile measurement tasks



License-free software

- Automatic process and quality control
- Individual alarm threshold settings depending on the respective process
- Analog and digital signal input
- External communication of software via COM ports, DLL and LabVIEW driver
- Compatible with Windows 7/10

Easy process integration via

Advanced interfaces

- USB cable extension up to 100 m (Ethernet)
- Process interface (PIF) as analog or digital input/output
- Serial data communication via RS232

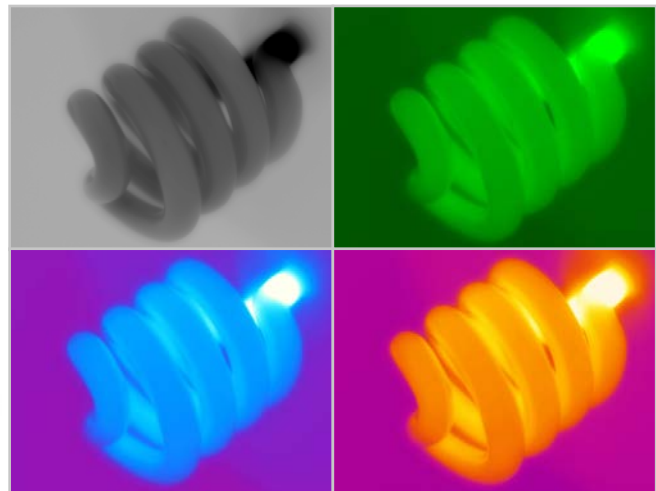

Large temperature measuring range

Thermal imaging cameras from Micro-Epsilon are suitable for use across a wide measuring range - from low temperatures prevalent in cooling chains or laboratories, to the highest temperatures in metal processing applications.

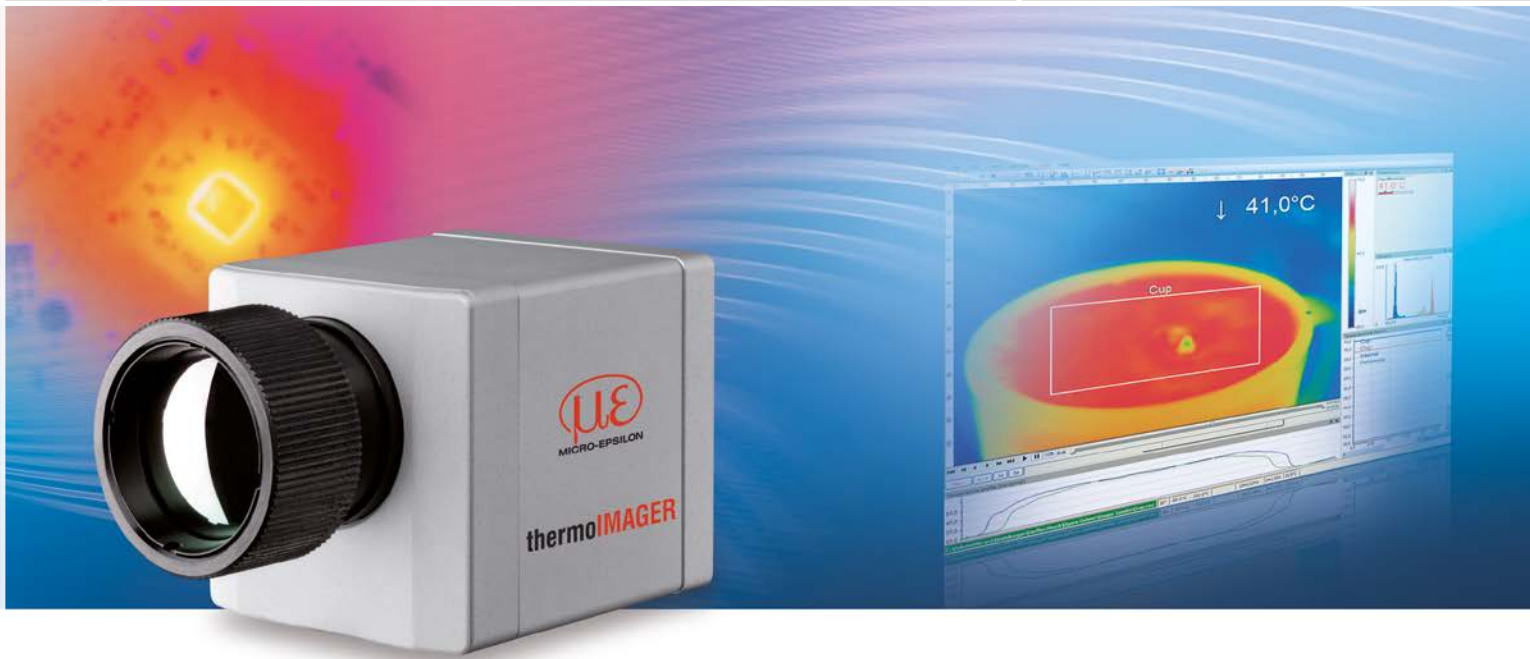

thermoIMAGER TIM 160

Miniaturized thermal imaging camera with USB interface

- Measuring range from -20 °C to 900 °C (special edition up to 1500 °C)
- Excellent thermal sensitivity (NEDT) of 0.08 K
- Exchangeable lenses 6°/23°/48°FOV or 72°FOV
- Real-time thermography with 120 Hz frame rate via USB 2.0 interface
- Power supply and data transfer via USB interface
- Extremely lightweight (195 g) and robust (IP67)
- Extremely compact dimensions 45x45x62 mm
- Analog input and output, trigger interface
- Software Developer Kit and LabVIEW examples included

Software

- Display of the thermal image in real time (120 Hz) with recording function (video, snapshot)
- Complete set up of parameters and remote control of the camera
- Detailed analysis of fast, thermodynamic processes
- Output of analog temperature or alarm values via the process interface
- Digital communication via RS232 or DLL for software integration

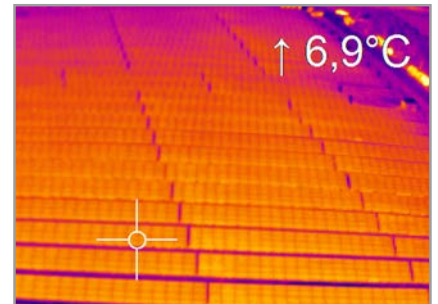

Surface measurements in industrial applications

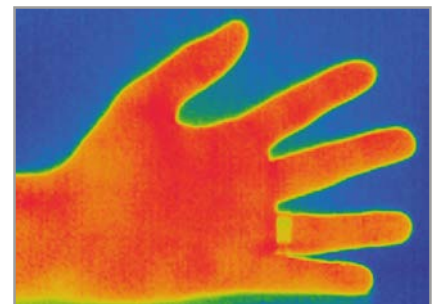

Suitable lenses for every measurement distance

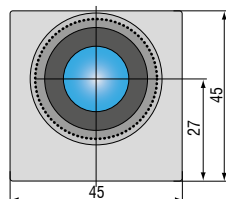
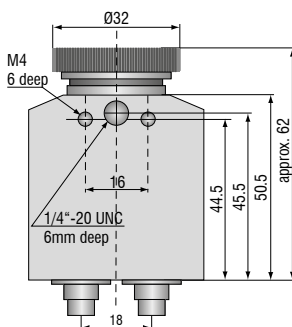

Model	TIM 160
Optical resolution	160 x 120 pixels
Temperature ranges	-20 °C to 100 °C / 0 °C to 250 °C / 150 °C to 900 °C additional range: 200 °C to 1500 °C (option)
Spectral range	7.5 to 13 μm
Frame rate	120 Hz
System accuracy	± 2 °C or ± 2 %, whichever is greater
Resolution (Display)	0.1 °C
Lenses	72° / f = 3.3 mm (min. distance 20 mm); 48° / f = 5.7 mm (min. distance 20 mm); 23° / f = 10 mm (min. distance 20 mm); 6° / f = 35.5 mm (min. distance 500 mm)
Emissivity	0.10 to 1.00 adjustable
Thermal sensitivity (NETD)	0.1 K with 48° FOV and 72° FOV ¹⁾ / 0.08 K with 23° FOV ¹⁾ / 0.3 K with 6° FOV ²⁾
Detector	Focal Plane Array (FPA) - uncooled micro bolometer 25x25 μm^2
Measurement mode	Flexible spot with crosshair marking, measuring field with automatic display of maximum-, minimum- or average value
Color palettes	Iron, rainbow, black-white, black-white inverted etc.
Operation and set up (via menu)	Measurement modes fully automatic or manual, color palettes, emissivity, file management, date/time, °C/°F, language
Outputs/digital	USB 2.0 / optional GigE
Process interface (electrically isolated)	0-10 V output, 0-10 V input
Digital communication	via RS232 of PC / DLL interface used
Cable length	1 m (standard), 5 m, 10 m, 20 m
Power supply	USB powered
Tripod mount	1/4"-20 UNC
Protection class	IP67
Ambient temperature range	0 °C to 50 °C (up to 315 °C with cooling jacket)
Storage temperature	-40 °C to 70 °C
Relative humidity	20 to 80 %, non-condensing
Vibration	IEC 60068-2-6 (sinus-shaped) / IEC 60068-2-64 (broadband noise)
Shock	IEC 60068-2-27 (25 g and 50 g)
Weight	195 g, incl. lens

PC requirements: minimum 1.5GHz, 1GB RAM, Windows XP SP 2 or Windows 7

¹⁾ Please note: measurement accuracy can be out of specification with distances below 200 mm

²⁾ Please note: measurement accuracy can be out of specification with distances below 500 mm

Scope of supply

TIM 160

- TIM process camera
incl. a selectable lens
- Instruction Manual
- USB cable 1 m
- Software for real-time processing
and analyzing thermal images
- Tripod mount
- PIF cable 1 m
- Transport case

TIM 160/DK

- TIM process camera
incl. three lenses 6°, 23°, 48°
- Certificate of calibration,
adjusted to the included lenses
- Tripod mount 200 to 1000 mm
- Transport case
- Instruction Manual
- USB cable 1 m and 10 m
- Software for real-time processing
and analyzing thermal images
- PIF cable 1 m

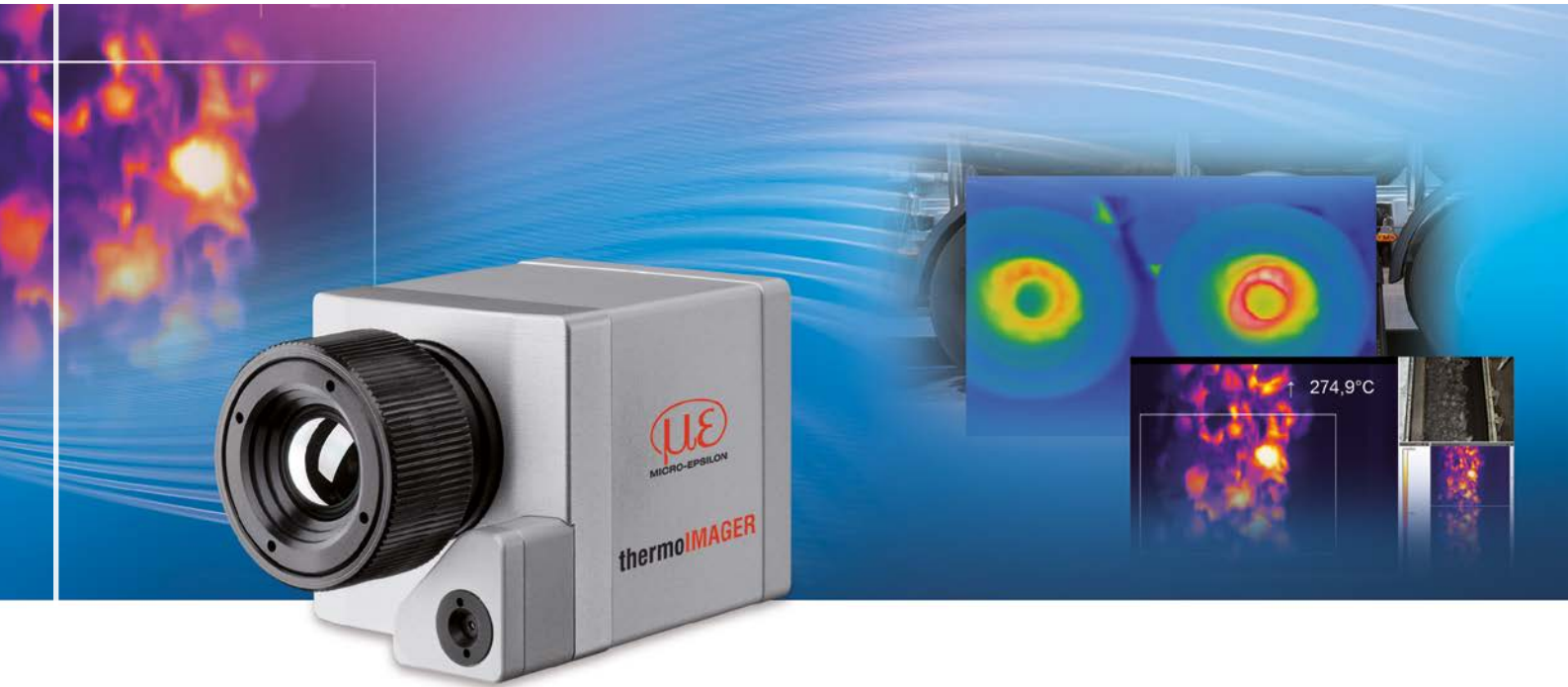

thermoIMAGER TIM 200/230

Thermal imager with BI-SPECTRAL technology

- Parallel detection in the IR field and the visual field
- Measuring range from -20 °C to 900 °C (special model up to 1500 °C)
- Excellent thermal sensitivity (NEDT) of 0.08 K
- Exchangeable lenses 6°/23°/48°FOV or 72°FOV
- Real-time thermography with 128 Hz frame rate via USB 2.0 interface
- Time synchronous, real-time image recording (VIS) with 32 Hz (640 x 480 pixels)
- Power supply and operation via USB interface
- Extremely lightweight (215 g) and robust (IP67)
- Extremely compact dimensions 45x45x62 mm
- Analog input and output, trigger interface
- Software Developer Kit and LabVIEW examples included

Software

- Display of the thermal image (128 Hz) and the real-time image (32 Hz) in real time with recording function (video, snapshot)
- Complete set up of parameters and remote control of the camera
- Detailed analysis of fast, thermodynamic processes
- Output of analog temperature or alarm values via the process interface
- Digital communication via RS232 or DLL for software integration

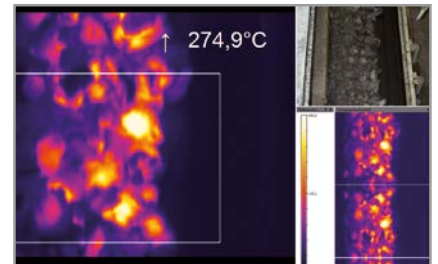

Monitoring modus

Monitoring a coal conveyor belt

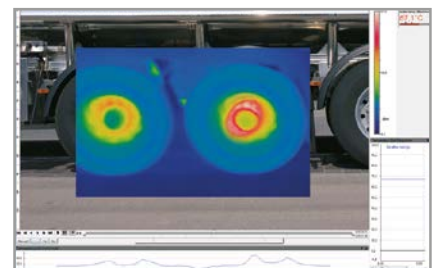

Cross-fading modus

Highlighting brake temperature by cross-fading

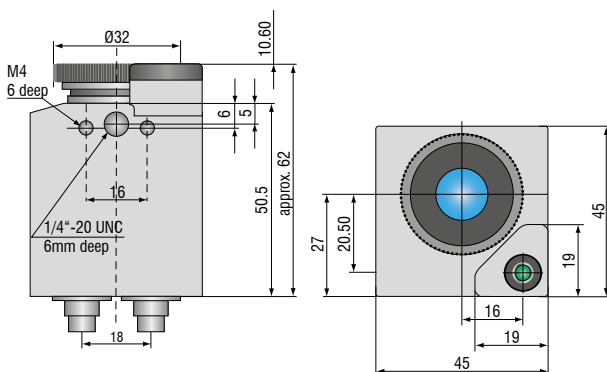

Model	TIM 200	TIM 230
Visual camera	Optical resolution: 640 x 480 pixels; frame rate: 32 Hz	
	Lens (FOV): 54° x 40°	Lens (FOV): 30° x 23°
Optical resolution (IR)	160 x 120 pixels	
Temperature ranges	-20 °C to 100 °C / 0 °C to 250 °C / 150 °C to 900 °C additional range: 200 °C to 1500 °C (option)	
Spectral range	7.5 to 13 μm	
Frame rate	128 Hz	
System accuracy	±2 °C or ±2 %, whichever is greater	
Resolution (Display)	0.1 °C	
Lenses	72° / f = 3.3 mm (min. distance 20 mm); 48° / f = 5.7 mm (min. distance 20 mm); 23° / f = 10 mm (min. distance 20 mm); 6° / f = 35.5 mm (min. distance 500 mm)	
Emissivity	0.10 to 1.00 adjustable	
Thermal sensitivity (NETD)	0.1 K with 48° FOV and 72° FOV ¹⁾ / 0.08 K with 23° FOV ¹⁾ / 0.3 K with 6° FOV ²⁾	
Detector	Focal Plane Array (FPA) - uncooled micro bolometer 25x25 μm ²	
Measurement mode	Flexible spot with crosshair marking, measuring field with automatic display of maximum-, minimum- or average value	
Color palettes	Iron, rainbow, black-white, black-white inverted etc.	
Operation and set up (via menu)	Measurement modes fully automatic or manual, color palettes, emissivity, file management, date/time, °C/F, language	
Outputs/digital	USB 2.0 / optional GigE	
Process interface (electrically isolated)	0-10 V output, 0-10 V input, trigger input	
Digital communication	via RS232 of PC / DLL interface used	
Cable length	1 m (standard), 5 m, 10 m, 20 m	
Power supply	USB powered	
Tripod mount	¼-20 UNC	
Protection class	IP67	
Ambient temperature range	0 °C to 50 °C (up to 315 °C with cooling jacket)	
Storage temperature	-40 °C to 70 °C	
Relative humidity	20 to 80 %, non-condensing	
Vibration	IEC 60068-2-6 (sinus-shaped) / IEC 60068-2-64 (broadband noise)	
Shock	IEC 60068-2-27 (25 g and 50 g)	
Weight	215 g, incl. lens	

PC requirements: minimum 1.5 GHz, 1 GB RAM, Windows XP SP 2 or Windows 7

¹⁾ Please note: measurement accuracy can be out of specification with distances below 200 mm

²⁾ Please note: measurement accuracy can be out of specification with distances below 500 mm

Scope of supply

TIM 200/230

- TIM process camera
incl. a selectable lens
- Instruction Manual
- USB cable 1 m
- Software for real-time processing
and analyzing thermal images
- Tripod mount
- PIF cable 1 m
- Transport case

TIM 200/DK

- TIM process camera
incl. three lenses 6°, 23°, 48°
- Certificate of calibration,
adjusted to the included lenses
- Tripod mount 200 to 1000 mm
- Transport case
- Instruction Manual
- USB cable 1 m and 10 m
- Software for real-time processing
and analyzing thermal images
- PIF cable 1 m



thermoIMAGER TIM 400/450

Thermal imaging camera with high resolution and sensitivity

- Detector with 382 x 288 pixels
- Measuring range from -20 °C to 900 °C (special model up to 1500 °C)
- Fast, real-time thermal imager with up to 80 Hz
- Very high thermal sensitivity with 80mK (TIM 400) and 40mK (TIM 450)
- Smallest camera in its class (46 x 56 x 90 mm)
- Lightweight (320 g incl. lens)
- Exchangeable lenses & industrial accessories
- Software TIMConnect included
- Software Developer Kit and LabVIEW examples included

Software

- Display of the thermal image in real time (80 Hz) with recording function (video, snapshot)
- Complete set up of parameters and remote control of the camera
- Detailed analysis of fast, thermodynamic processes
- Output of analog temperature or alarm values via the process interface
- Digital communication via RS232 or DLL for software integration

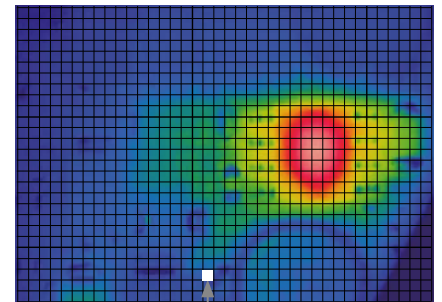

382 x 288 pixels

10 x 10 pixels = 40 mm²

SMD element as measurement object

Measuring field size: 240 mm x 180 mm,
pixel size: 0.63 mm

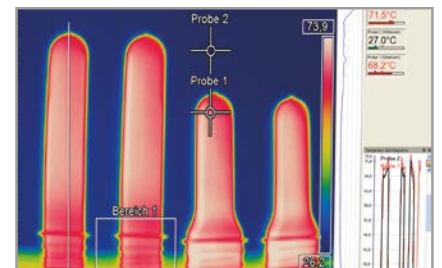

80 Hz imaging with full pixel resolution

Thermal image shots of preforms
in PET bottle production

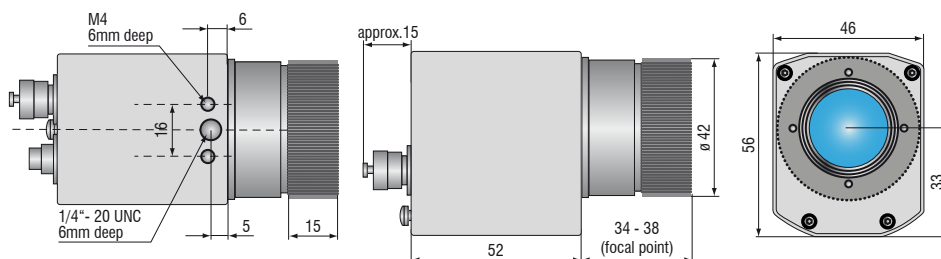

Model	TIM 400	TIM 450
Optical resolution	382 x 288 pixels	
Temperature ranges	-20 °C to 100 °C / 0 °C to 250 °C / 150 °C to 900 °C additional range: 200 °C to 1500 °C (option only for TIM 400)	
Spectral range	7.5 to 13 μ m	
Frame rate	switchable 80 Hz or 27 Hz	
System accuracy	± 2 °C or ± 2 %, whichever is greater	
Lenses	80° x 56° FOV / f = 7.7 mm ¹⁾ or 53° x 40° FOV / f = 10.5 mm ¹⁾ or 29° x 22° FOV / f = 18.7 mm ¹⁾ or 13° x 10° FOV / f = 41 mm ²⁾	
Thermal sensitivity (NETD)	0.08 K with 29°, 53°, 80° FOV / F = 0.8 0.1 K with 13° FOV / F = 1.0	0.04K with 29°, 53°, 80° FOV / F = 0.8 0.06K with 13° FOV / F = 1.0
Detector	Focal Plane Array (FPA) - uncooled micro bolometer 25x25 μ m ²	
Outputs/digital	USB 2.0 / optional GigE	
Process interface (electrically isolated)	0-10 V output, 0-10 V input, trigger input	
Power supply	USB powered	
Tripod mount	¼-20 UNC	
Protection class	IP67	
Ambient temperature range	0 °C to 50 °C	0 °C to 70 °C
Storage temperature	-40 °C to 70 °C	-40 °C to 85 °C
Relative humidity	20 to 80 %, non-condensing	
Vibration	IEC 60068-2-6 (sinus-shaped) / IEC 60068-2-64 (broadband noise)	
Shock	IEC 60068-2-27 (25 g and 50 g)	
Housing (size)	46 mm x 56 mm x 90 mm	
Weight	320 g, incl. lens	

PC requirements: minimum 1.5 GHz, 1 GB RAM, Windows XP SP 2 or Windows 7

¹⁾ Please note: measurement accuracy can be out of specification with distances below 200 mm

²⁾ Please note: measurement accuracy can be out of specification with distances below 500 mm

Scope of supply

TIM 400/450

- TIM process camera
incl. a selectable lens
- Instruction Manual
- USB cable 1 m
- Software for real-time processing
and analyzing thermal images
- Tripod mount
- PIF cable 1 m
- Transport case

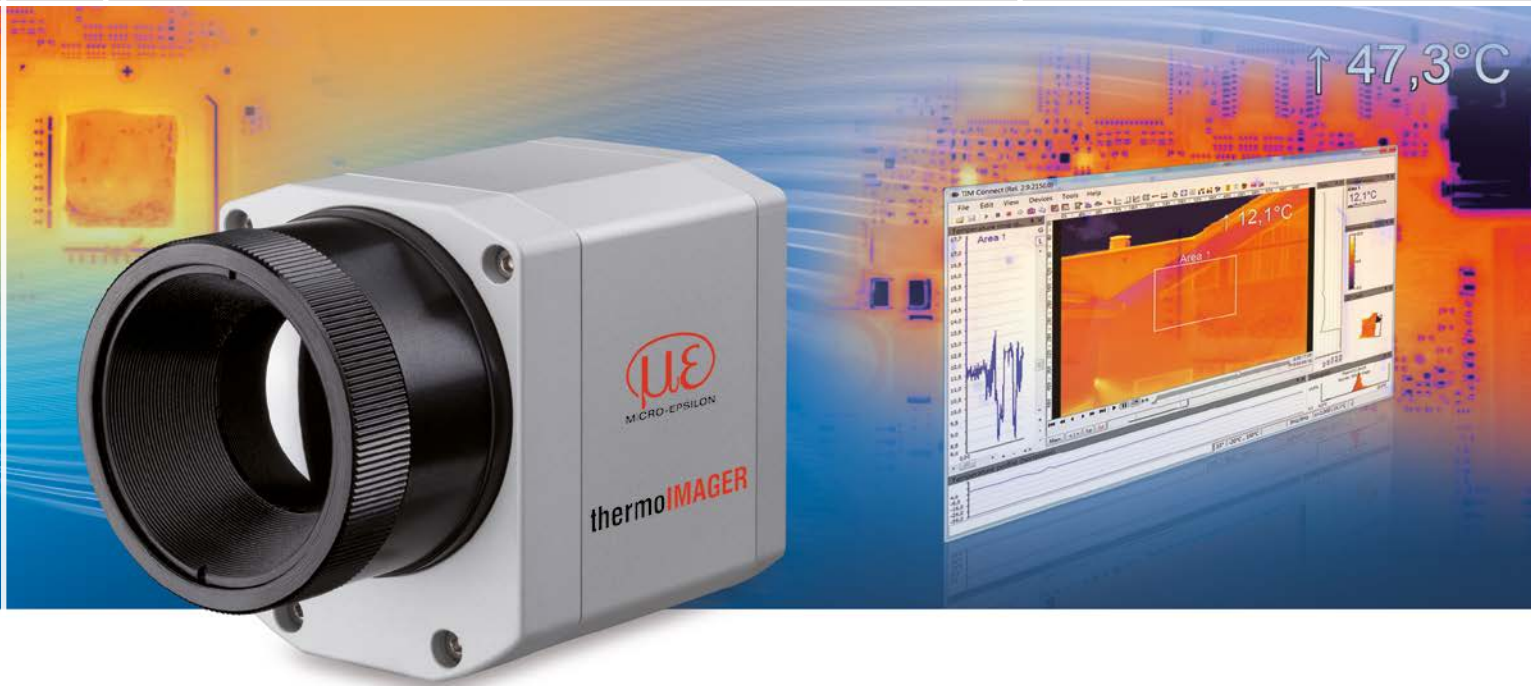

thermoIMAGER TIM 640

Miniature infrared camera with VGA resolutions

- Thermography in VGA resolution
- 640 x 480 pixels
- Measuring range from -20 °C to 900 °C (special model up to 1500 °C)
- Radiometric video recording with 32 Hz, 125Hz in the subframe mode (640x120 pixels)
- Compact design (46 x 56 x 90 mm) with USB interface
- Lightweight (320 g incl. lens)
- Exchangeable lenses & industrial accessories
- Software TIMConnect included
- Software Developer Kit and LabVIEW examples included

Software

- Display of the thermal image in real time (32 Hz) with recording function (video, snapshot)
- Complete set up of parameters and remote control of the camera
- Detailed analysis of fast, thermodynamic processes
- Output of analog temperature or alarm values via the process interface
- Digital communication via RS232 or DLL for software integration

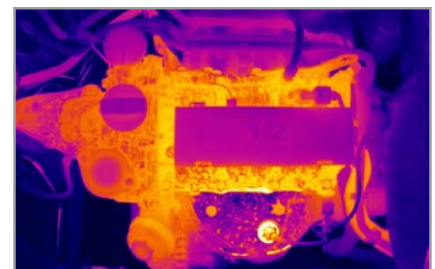
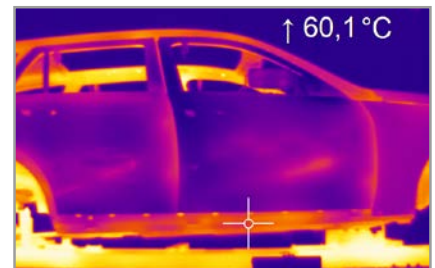

Razor-sharp infrared pictures and videos for process optimization e.g. in the automotive industry

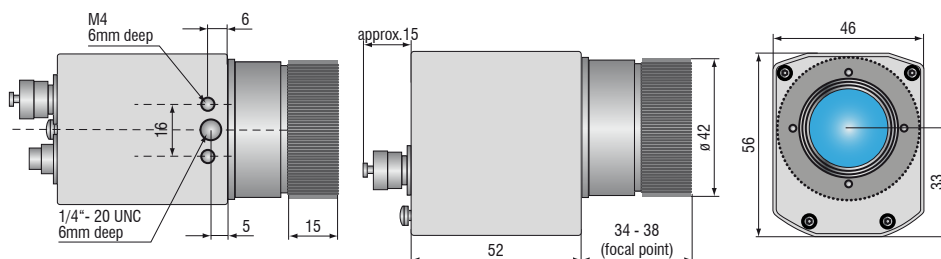

Model	TIM 640
Optical resolution	640 x 480 pixels
Temperature ranges	-20 °C to 100 °C / 0 °C to 250 °C / 150 °C to 900 °C additional range: 200 °C to 1500 °C (option)
Spectral range	7.5 to 13 μ m
Frame rate	32 Hz / 125 Hz in the subframe mode (640x120 pixels)
System accuracy	± 2 °C or ± 2 %, whichever is greater
Lenses	15° x 11° FOV / f = 41.5 mm or 33° x 25° FOV / f = 18.7 mm or 60° x 45° FOV / f = 10.5 mm or 90° x 64° FOV / f = 7.7 mm ¹⁾
Thermal sensitivity (NETD)	75 mK
Detector	FPA, uncooled (17 μ m x 17 μ m)
Outputs/digital	USB 2.0 / optional GigE
Standard process interface (PIF)	0-10 V input, digital input (max. 24 V), 0-10 V output
Industry process interface (PIF)	2x 0-10 V inputs, digital input (max. 24 V), 3x 0(4)-20 mA outputs, 3x relays (0-30 V/ 400 mA), fail-safe relay
Cable length (USB)	1 m (standard), 5 m, 10 m 5 m and 10 m also as high temperature USB cable (180 °C)
Power supply	USB powered
Tripod mount	¼-20 UNC
Protection class	IP67
Ambient temperature range	0 °C to 50 °C
Storage temperature	-40 °C to 70 °C
Relative humidity	20 to 80 %, non-condensing
Vibration	IEC 60068-2-6 (sinus-shaped) / IEC 60068-2-64 (broadband noise)
Shock	IEC 60068-2-27 (25 g and 50 g)
Housing (size)	46 mm x 56 mm x 90 mm
Weight	320 g, incl. lens

PC requirements: minimum 1.5 GHz, 1 GB RAM, Windows XP SP 2 or Windows 7

¹⁾ Please note: measurement accuracy can be out of specification with distances below 200 mm

Scope of supply

TIM 640

- TIM process camera
incl. a selectable lens
- Instruction Manual
- USB cable 1 m
- Software for real-time processing
and analyzing thermal images
- Tripod mount
- PIF cable incl. terminal block (1 m)
- Transport case



thermoIMAGER TIM G7

Thermal imaging camera with line scan feature for the glass industry

- Line scan feature via license-free TIMConnect analysis software
- Compact size of 46 x 56 x 90 mm
- Frame rate up to 125 Hz
- Robust against ambient temperatures up to 70 °C without requiring additional cooling, up to 315 °C with cooling jacket
- Optional integration of a reference pyrometer for glass with a reflection coating
- Compact design (46 x 56 x 90 mm) with USB interface
- Lightweight (320 g incl. lens)
- Exchangeable lenses & industrial accessories
- Software TIMConnect included
- Software Developer Kit and LabVIEW examples included

Software

- Line scan feature
- Display of the thermal image in real time (80 Hz) with recording function (video, snapshot)
- Complete set up of parameters and remote control of the camera
- Detailed analysis of fast, thermodynamic processes
- Output of analog temperature or alarm values via the process interface
- Digital communication via RS232 or DLL for software integration

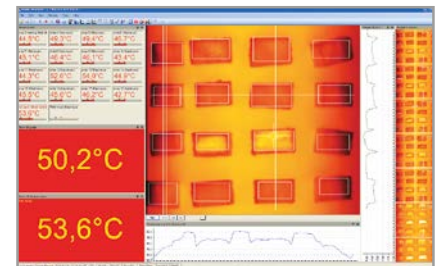

Exact temperature measurement on moving glass surfaces due to line scan feature

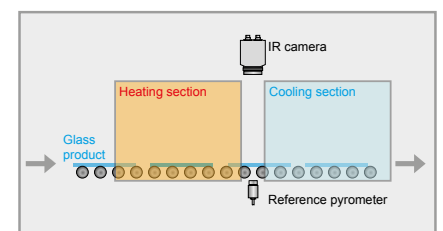

Line scan camera feature measures the temperature distribution between the heating zone and the cooling zone e.g. when toughened or tempered safety glass is heat-treated.

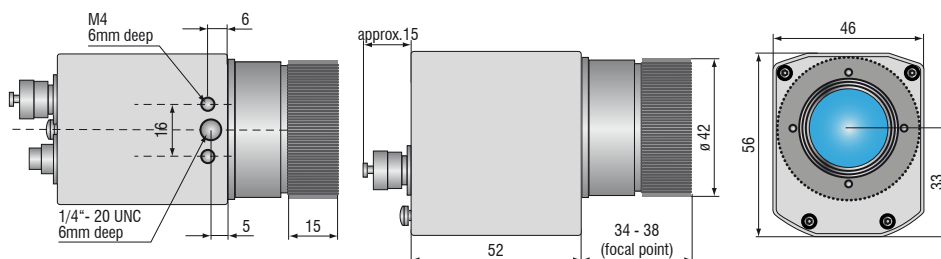

Model	TIM G7	TIM G7 VGA
Optical resolution	382 x 288 pixels	640 x 480 pixels
Temperature ranges	200 °C to 1500 °C	
Sighting range	0 °C to 250 °C (no measurement)	
Spectral range	7.9 μm	
Frame rate	switchable 80 Hz or 27 Hz	32 Hz / 125 Hz in the subframe mode (640x120 pixels)
System accuracy	±2 °C or ±2 %, whichever is greater	
Lenses	13° x 10° FOV / f = 41 mm ¹⁾ or 29° x 22° FOV / f = 18.7 mm ¹⁾ or 53° x 40° FOV / f = 10.5 mm ¹⁾ or 80° x 56° FOV / f = 7.7 mm ¹⁾	15° x 11° FOV / f = 42 mm ¹⁾ or 33° x 25° FOV / f = 18.7 mm ¹⁾ or 60° x 45° FOV / f = 10.5 mm ¹⁾ or 90° x 64° FOV / f = 7.7 mm ¹⁾
Thermal sensitivity (NETD)	130 mK	
Detector	FPA, uncooled (25 μm x 25 μm)	FPA, uncooled (17 μm x 17 μm)
Outputs/digital	USB 2.0 / optional GigE	
Standard process interface (PIF)	0-10 V input, digital input (max. 24 V), 0-10 V output	
Industry process interface (PIF)	2x 0-10 V inputs, digital input (max. 24 V), 3x 0(4)-20 mA outputs, 3x relays (0-30 V/ 400 mA), fail-safe relay	
Cable length (USB)	1 m (standard), 5 m, 10 m 5 m and 10 m also as high temperature USB cable (180 °C)	
Power supply	USB powered	
Tripod mount	¼-20 UNC	
Protection class	IP67	
Ambient temperature range	0 °C to 70 °C	0 °C up to 50 °C
Storage temperature	-40 °C to 85 °C	-40 °C to 70 °C
Relative humidity	20 to 80 %, non-condensing	
Vibration	IEC 60068-2-6 (sinus-shaped) / IEC 60068-2-64 (broadband noise)	
Shock	IEC 60068-2-27 (25 g and 50 g)	
Housing (size)	46 mm x 56 mm x 90 mm	
Weight	320 g, incl. lens	

PC requirements: minimum 1.5 GHz, 1 GB RAM, Windows XP SP 2 or Windows 7

¹⁾ Please note: measurement accuracy can be out of specification with distances below 200 mm

Scope of supply

TIM G7

- TIM process camera
incl. a selectable lens
- Instruction Manual
- USB cable 1 m
- Software for real-time processing
and analyzing thermal images
- Tripod mount
- PIF cable incl. terminal block (1 m)
- Transport case



thermoIMAGER TIM M1

Short wavelength infrared camera for high temperature measurements of metal surfaces

- Highly dynamic CMOS detector with optical resolution up to 764 x 480 pixels
- Very large temperature measuring range (without sub-ranges) from 450 °C to 1800 °C
- Frame rates up to 1 kHz for fast processes
- Real time output of the center pixel up to 1 kHz via process interface (PIF)
- License-free analysis software and complete SDK included

Software

- Display of the thermal image in real time with recording function (video, snapshot)
- Complete set up of parameters and remote control of the camera
- Detailed analysis of fast, thermodynamic processes
- Output of analog temperature or alarm values via the process interface
- Digital communication via RS232 or DLL for software integration

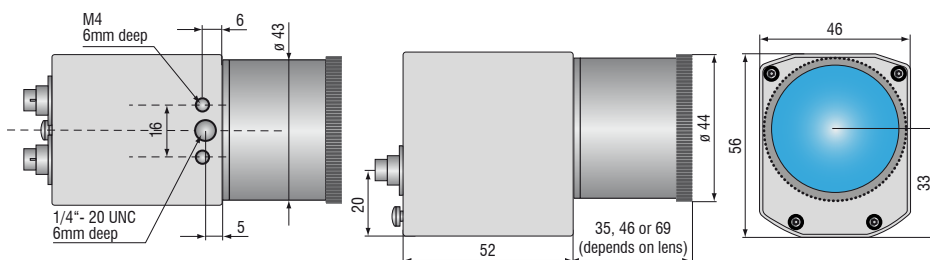
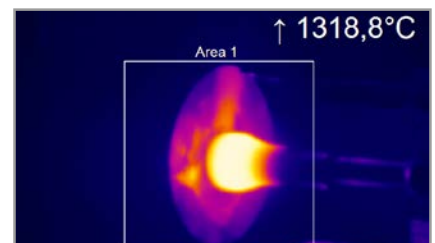
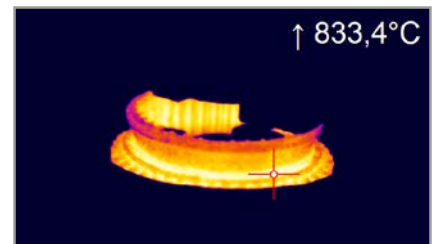
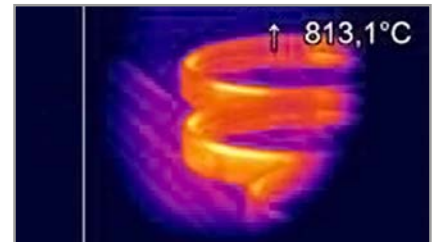

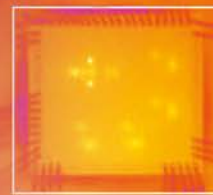

Model	TIM M1	
Optical resolution	764 x 480 pixels @ 32 Hz 382 x 288 pixels @ 80 Hz (switchable to 27 Hz) 72 x 56 pixels @ 1 kHz 764 x 8 pixels @ 1 kHz (fast line-scan mode)	
Temperature ranges	450 °C ⁵⁾ to 1800 °C (27 Hz mode) 500 °C ⁵⁾ to 1800 °C (80 Hz and 32 Hz mode) 600 °C ⁵⁾ up to 1800 °C (1 kHz mode)	
Spectral range	0.85 to 1.1 μm	
Frame rate	Up to 1 kHz / 1 ms real-time analog output (0 - 10 V) from 8 x 8 pixels (freely selectable)	
System accuracy	±1 % of reading (object temperature < 1400 °C)	
Lenses	FOV @ 764 x 480 px: 39° x 25° (f = 16 mm) ¹⁾ 26° x 16° (f = 25 mm) ²⁾ 13° x 8° (f = 50 mm) ³⁾ 9° x 5° (f = 75 mm) ⁴⁾	FOV @ 382 x 288 px: 20° x 15° (f = 16 mm) ¹⁾ 13° x 10° (f = 25 mm) ²⁾ 7° x 5° (f = 50 mm) ³⁾ 4° x 3° (f = 75 mm) ⁴⁾
Thermal sensitivity (NETD)	< 1 K (700 °C) < 2 K (1000 °C)	
Detector	CMOS (15 μm x 15 μm)	
Outputs/digital	USB 2.0 / optional GigE	
Standard process interface (PIF)	0-10 V input, digital input (max. 24 V), 0-10 V output	
Industry process interface (PIF)	2x 0-10 V inputs, digital input (max. 24 V), 3x 0-10 V outputs, 3x relays (0-30 V/ 400 mA), fail-safe relay	
Cable length (USB)	1 m (standard), 5 m, 10 m 5 m and 10 m also as high temperature USB cable (180 °C)	
Power supply	USB powered	
Tripod mount	¼-20 UNC	
Protection class	IP67	
Ambient temperature range	5 °C to 50 °C	
Storage temperature	-40 °C to 70 °C	
Relative humidity	20 to 80 %, non-condensing	
Vibration	IEC 60068-2-6 (sinus-shaped) / IEC 60068-2-64 (broadband noise)	
Shock	IEC 60068-2-27 (25 g and 50 g)	
Housing (size)	46 mm x 56 mm x 90 mm	
Weight	320 g, incl. lens	

PC requirements: minimum 1.5 GHz, 1 GB RAM, Windows XP SP 2 or Windows 7

¹⁾Please note: measurement accuracy can be out of specification with distances below 200 mm

²⁾Please note: measurement accuracy can be out of specification with distances below 500 mm

³⁾Please note: measurement accuracy can be out of specification with distances below 1500 mm

⁴⁾Please note: measurement accuracy can be out of specification with distances below 2000 mm

⁵⁾+75 °C higher initial temperature with lenses providing a focal length of f= 50 mm and f=75 mm

Scope of supply

TIM M1

- TIM process camera
incl. a selectable lens
- Lens cap incl. protective window
- Instruction Manual
- USB cable 1 m
- Software for real-time processing and
analyzing thermal images
- Tripod mount
- PIF cable incl. terminal block (1 m)
- Transport case
- Optional:
Cooling Jacket, high temperature cable

thermoIMAGER TIM M-1-N1064

Special model with laser blocking filter at wavelength of 1064 nm
(focal length of only 16 mm and 25 mm)

- Measurement during active laser (neodymium-YAG laser)
- High measurement speeds up to 1 kHz

thermoIMAGER TIM M-1-B880

Special model with blocking filter from 1000 nm to 1200 nm (focal length of only 25 mm)

- For neodymium-YAG laser types and diode laser types

Model	TIM M-1-N1064	TIM M-1-B880
Optical resolution	764 x 480 pixels @ 32 Hz 382 x 288 pixels @ 80 Hz (switchable to 27 Hz) 72 x 56 pixels @ 1 kHz 764 x 8 pixels @ 1 kHz (fast line-scan mode)	
Temperature ranges	450 °C ²⁾ to 1800 °C (27 Hz mode) 500 °C ²⁾ to 1800 °C (32 Hz mode) 500 °C ²⁾ to 1800 °C (80 Hz mode) 700 °C ²⁾ to 1800 °C (1 kHz mode)	525 °C ²⁾ to 1800 °C (27 Hz mode) 600 °C ²⁾ to 1800 °C (32 Hz mode) 550 °C ²⁾ to 1800 °C (80 Hz mode) 625 °C ²⁾ to 1800 °C (1 kHz mode)
Spectral range	0.92 - 1.1 µm with blocking filter at 1064 nm / FWHM = 44 nm	0.92 - 1.1 µm with blocking filter at 1000-1200 nm bandpass filter: CWL = 880 ± 8 nm, FWHM = 70 ± 8 nm
Frame rate	Up to 1 kHz / 1ms real-time analog output (0 - 10 V) from 8 x 8 pixels (freely selectable)	
System accuracy	±1 % of reading (object temperature < 1400 °C)	
Lenses	FOV @ 764 x 480 px: 26° x 16° (f = 25 mm) ¹⁾ FOV @ 382 x 288 px: 13° x 10° (f = 25 mm) ¹⁾	
Thermal sensitivity (NETD)	< 1 K (700 °C) < 2 K (1000 °C)	
Detector	CMOS (15 µm x 15 µm)	
Outputs/digital	USB 2.0 / optional GigE	
Standard process interface (PIF)	0-10 V input, digital input (max. 24 V), 0-10 V output	
Industry process interface (PIF)	2x 0-10 V inputs, digital input (max. 24 V), 3x 0(4)-20 mA outputs, 3x relays (0-30 V/ 400 mA), fail-safe relay	
Cable length (USB)	1 m (standard), 5 m, 10 m 5 m and 10 m also as high temperature USB cable (180 °C)	
Power supply	USB powered	
Tripod mount	¼-20 UNC	
Protection class	IP67	
Ambient temperature range	0 °C to 50 °C	5 °C to 50 °C
Storage temperature	-40 °C to 70 °C	
Relative humidity	20 to 80 %, non-condensing	
Vibration	IEC 60068-2-6 (sinus-shaped) / IEC 60068-2-64 (broadband noise)	
Shock	IEC 60068-2-27 (25 g and 50 g)	
Housing (size)	46 mm x 56 mm x 90 mm	
Weight	320 g, incl. lens	

PC requirements: minimum 1.5 GHz, 1 GB RAM, Windows XP SP 2 or Windows 7 & 10

¹⁾ Please note: measurement accuracy can be out of specification with distances below 500 mm

²⁾ +75 °C higher initial temperature with lenses providing a focal length of f= 50 mm and f=75 mm

Scope of supply**TIM M1**

- TIM process camera
- Lens cap incl. protective window
- Instruction Manual
- USB cable 1 m
- Software for real-time processing and analyzing thermal images
- Tripod mount
- PIF cable incl. terminal block (1 m)
- Transport case
- Optional: Cooling Jacket, high temperature cable

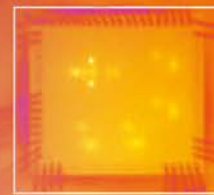

Cooling Jacket and Cooling Jacket Advanced Universal cooling housing for infrared cameras up to 315 °C

- Ambient operating temperatures up to 315 °C
- Also available with protection housing and cooling function up to 180 °C
- Air/Water cooling with integrated air purging and optional protective windows
- Modular design for easy fitting of different devices and lenses
- Easy sensor removal on site due to quick-release chassis
- Integration of additional components like TIM NetBox, USB Server Gigabit and Industrial Process Interface (PIF) in the extended version



Model	Cooling Jacket	Cooling Jacket Advanced Standard	Cooling Jacket Advanced Extended
Protection class	IP65	IP65	IP65
Ambient temperature range	up to 180 °C	up to 315 °C ¹⁾	up to 315 °C ¹⁾
Relative humidity	10 to 95 %, non-condensing	10 to 95 %, non-condensing	10 to 95 %, non-condensing
Material (housing)	V2A	V2A	V2A
Dimensions	237 mm x 117 mm x 138 mm	271 mm x 166 mm x 182 mm	426 mm x 166 mm x 182 mm
Weight	4.5 kg	5.7 kg	7.8 kg
Air purge collar	G1/4" internal thread G3/8" external thread	G1/4" internal thread G3/8" external thread	G1/4" internal thread G3/8" external thread
Cooling water fittings	G1/4" internal thread G3/8" external thread	G1/4" internal thread G3/8" external thread	G1/4" internal thread G3/8" external thread
Cooling water pressure	max. 15 bar (217 psi)	max. 15 bar (217 psi)	max. 15 bar (217 psi)
Scope of supply	<ul style="list-style-type: none"> ▪ Cooling Jacket, consisting of housing and chassis 	<ul style="list-style-type: none"> ▪ Cooling Jacket Advanced, consisting of housing with mounting angle, chassis ▪ Assembly instructions 	<ul style="list-style-type: none"> ▪ Cooling Jacket Advanced, consisting of housing with mounting angle, chassis ▪ Mounting accessories for TIM NetBox or USB Server Gigabit and Industry PIF ▪ Assembly instructions
		<ul style="list-style-type: none"> ▪ Focusing unit or front attachment ²⁾ 	<ul style="list-style-type: none"> ▪ Focusing unit or front attachment ²⁾

¹⁾ Cable for up to 250 °C ambient temperature as well as cable cooling for up to 315 °C available.

²⁾ Must be ordered separately.

Cooling Jacket

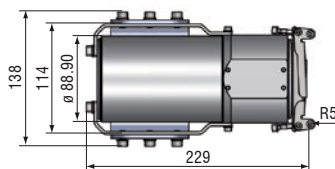

Cooling Jacket Advanced – Standard version

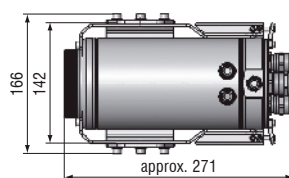

Cooling Jacket Advanced – Extended version

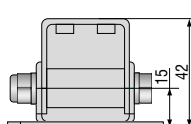
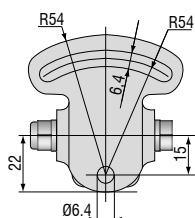
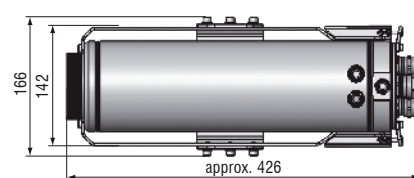

TM-MB-TIM adjustable mounting foot

TM-PH-TIM protection housing incl. mounting foot



thermoIMAGER TIM M05

Compact infrared camera for the short-wave range for non-contact temperature measurement of molten metal and metallic surfaces from 900 °C to 2000 °C

- Highly dynamic CMOS detector with resolution up to 764 x 480 pixels
- Special wavelength range from 500 nm to 540 nm minimizes errors due to unknown emissivity
- Wide measuring range from 900 °C to 2000 °C (without sub-ranges)
- Frame rates up to 1 kHz for fast processes
- Real-time analog output with 1 ms response time
- Comprehensive software package and SDK
- Ideally suitable for laser processing applications as radiation above 540 nm is blocked excellently

Software

- Display of the thermal image in real time with recording function (video, snapshot)
- Complete set up of parameters and remote control of the camera
- Detailed analysis of fast, thermodynamic processes
- Output of analog temperature or alarm values via the process interface
- Digital communication via RS232 or DLL for software integration

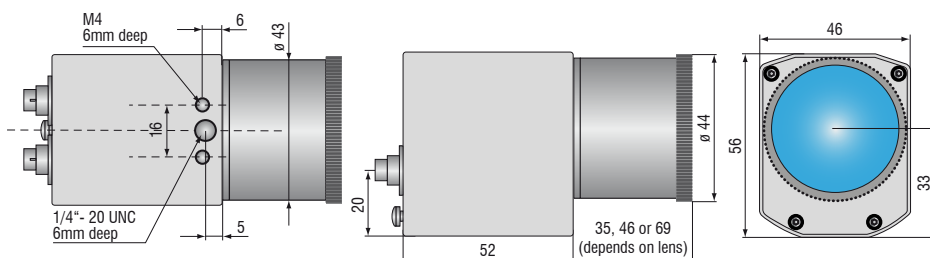
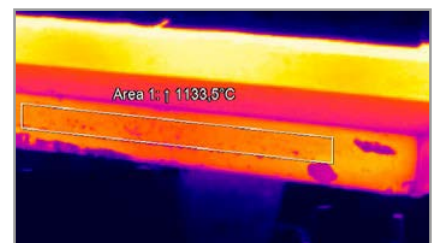
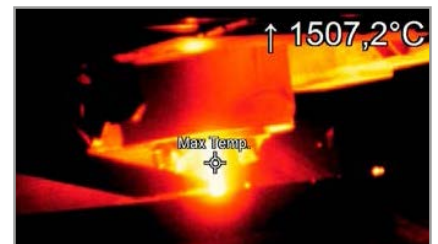
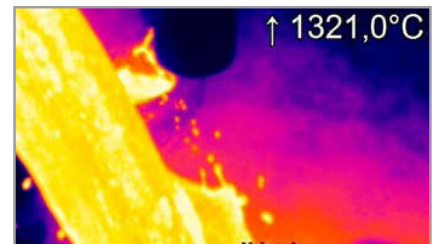

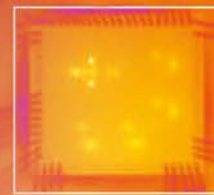

Model	TIM M05	
Optical resolution	764 x 480 pixels @ 32 Hz 382 x 288 pixels @ 80 Hz (switchable to 27 Hz) 72 x 56 pixels @ 1 kHz ¹⁾ 764 x 8 pixels @ 1 kHz (fast line-scan mode) ¹⁾	
Temperature ranges	900 °C to 2000 °C (27 Hz mode) 950 °C up to 2000 °C (80 Hz and 32 Hz mode) 1100 °C up to 2000 °C (1 kHz mode)	
Spectral range	500 to 540 nm	
Frame rate	Up to 1 kHz / 1 ms real-time analog output (0 - 10 V) from 8 x 8 pixels (freely selectable)	
System accuracy	±1.5 % of reading	
Lenses	FOV @ 764 x 480 px: 26° x 16° (f = 25 mm) ³⁾	FOV @ 382 x 288 px: 13° x 10° (f = 25 mm) ³⁾
Thermal sensitivity (NETD)	< 2 K (1400 °C) for 27 Hz, 32 Hz and 80 Hz < 2.5 K (1400 °C) for 1 kHz	
Detector	CMOS (15 μm x 15 μm)	
Outputs/digital	USB 2.0 / optional GigE	
High-speed analog output (@ 1kHz mode)	1ms real-time analog output (0 – 10 V) of 8 x 8 pixels (freely selectable positions)	
Standard process interface (PIF)	0-10 V input, digital input (max. 24 V), 0-10 V output	
Industry process interface (PIF)	2x 0-10 V inputs, digital input (max. 24 V), 3x 0(4)-20 mA outputs, 3x relays (0-30 V/ 400 mA), fail-safe relay	
Cable length (USB)	1 m (standard), 5 m, 10 m 5 m and 10 m also as high temperature USB cable (180 °C)	
Power supply	USB powered	
Tripod mount	¼-20 UNC	
Protection class	IP67 ²⁾	
Ambient temperature range	5 °C to 50 °C	
Storage temperature	-40 °C to 70 °C	
Relative humidity	20 to 80 %, non-condensing	
Vibration	IEC 60068-2-6 (sinus-shaped) / IEC 60068-2-64 (broadband noise)	
Shock	IEC 60068-2-27 (25 g and 50 g)	
Housing (size)	46 mm x 56 mm x 90 mm	
Weight	320 g, incl. lens	

PC requirements: minimum 1.5 GHz, 1 GB RAM, Windows XP SP 2 or Windows 7

¹⁾ Can be placed anywhere within the FOV

²⁾ Only applies when lens protection tube is used

³⁾ Please note: measurement accuracy can be out of specification with distances below 500 mm

Scope of supply

TIM M05

- TIM process camera
incl. a selectable lens
- Lens cap incl. protective window
- Instruction Manual
- USB cable 1 m
- Software for real-time processing and
analyzing thermal images
- Tripod mount
- PIF cable incl. terminal block (1 m)
- Transport case
- Optional:
Cooling Jacket, high temperature cable

thermoIMAGER TIM USB Server Gigabit**Simple cable extension for the thermoIMAGER TIM series and pyrometers**

- Fully compatible with USB 2.0, data transfer rate 1.5/ 12/ 480mbps,
USB transfer modes: Control, Bulk, Interrupt, Isochronous
- For all models in the thermoIMAGER TIM series 1x TIM640, 1x TIM4xx, 2x TIM160, 1x TIM200
- Full TCP/IP support incl. routing and DNS
- Two independent USB ports
- Galvanic isolation 500V_{RMS} (network connection)
- Remote configuration via web-based management

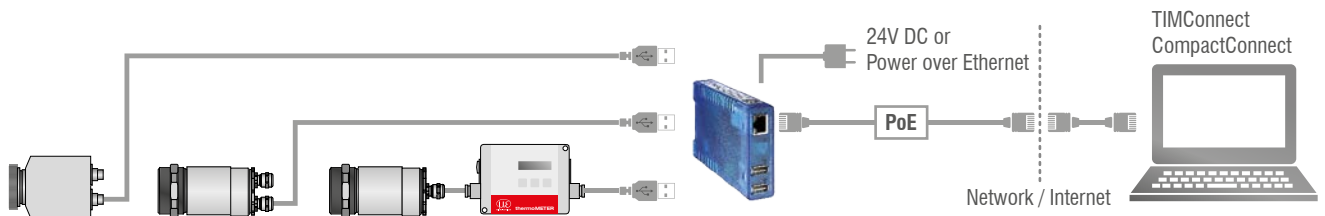

Model	TIM USB Server Gigabit
USB ports	Two independent USB ports
USB speed	480 Mbit/s
Network	10/100/1000 BaseT (max. 1000 Mbit/s)
Power supply	Power over Ethernet (PoE) class 3 (6.49 - 12.95 W) or via screw terminal DC 24 V ... 48 V ($\pm 10\%$)
Power consumption	External power supply (24 V DC) without USB devices: typ. 120 mA External power supply (24 V DC) with 2 USB devices each 2.5 W: typ. 420 mA
Ambient temperature range	Storage: -40 ... 85 °C In operation, individually assembled: 0 ... 50 °C
Permissible relative humidity	0 - 95 % (non-condensing)
Housing	Compact plastic housing for DIN rail mount, 105 x 75 x 22 mm
Weight	200 g
Scope of supply	1 x USB Server Gigabit 24 V DC power supply unit Quick guide ¹⁾
USB protocols	USB 1.0 / 1.1 / 2.0 Control / Bulk / Interrupt / Isochronous
Protocols for direct network connection	TCP/IP: Socket Auxiliary protocols: ARP, DHCP, HTTP, PING Inventory keeping, group management

¹⁾ TIMConnect CD or Compact Connect CD: USB redirector | WuTility Management Tool | Operating instructions (DE/EN)

Industrial process interface

Camera and process control for use in industrial environments

- Industrial process interface with 3 analog / alarm outputs, 2 analog inputs, 1 digital input, 3 alarm relays
- 500V AC_{RMS} galvanic isolation between TIM camera and process
- Separate fail-safe relay output
- TIM hardware with all cable connections and the TIMConnect software are permanently monitored during operation

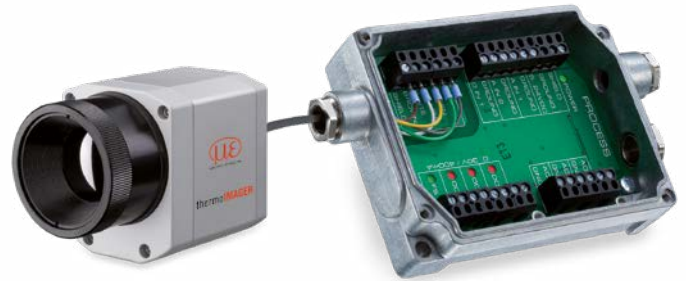

Exemplary fail-safe monitoring of the TIM camera with connected PLC

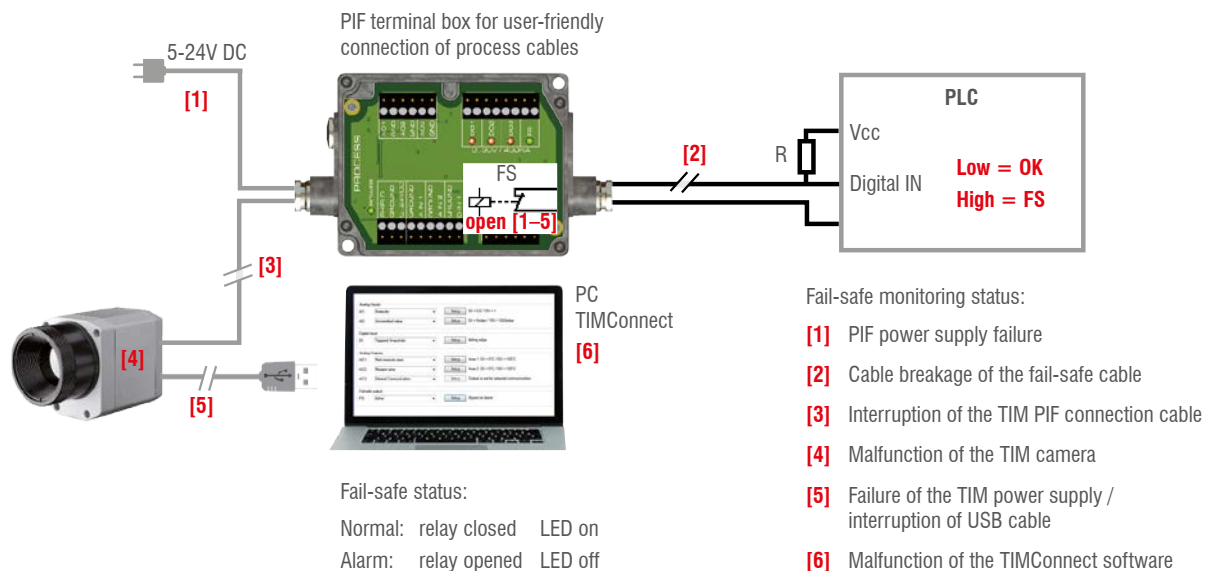

Model	Industrial process interface
Protection class	IP65 (NEMA-4)
Ambient temperature range	-30 °C to 85 °C
Storage temperature	-30 °C to 85 °C
Relative humidity	10 to 95 %, non-condensing
Vibration resistance	IEC 60068-2-6 (non-condensing)/ IEC 60068-2-64 (broadband noise)
Shock	IEC 60068-2-27 (25 g and 50 g)
Weight	610 g (with 5 m cable)
Cable length	5 m, optional 10 m and 20 m or HT cable (180 °C or 250 °C)
Power supply	5 to 24 VDC
LED indicators	2 green LEDs for voltage and fail safe / 3 red LEDs for alarm relay status
Insulation	500V AC _{RMS} between TIM camera and process
Outputs	3 analog / alarm outputs 3 alarm relays ¹⁾
Inputs	2 analog input 1 digital input
Ranges	0/4-20 mA (for AO 1 – 3) ¹⁾ 0 – 30 V / 400 mA (for alarm relays DO 1 – 3) 0 – 10 V (for AI 1 – 2) 24 V (for DI)
Analog inputs	Emissivity setting Ambient temperature compensation Reference temperature Uncommitted value Flag control Triggered snapshots, triggered recordings, triggered line scan camera, triggered event grabber Reset peak-/valley-hold
Digital input	Flag control Triggered snapshots, triggered recordings, triggered line scan camera, triggered event grabber Reset peak-/valley-hold
Analog outputs	Main measuring range Measuring range Internal temperature Flag status Alarm Frame synchronization Fail safe External communication Center pixel (direct output) ²⁾

¹⁾ active when AO1, 2 or 3 is / are programmed as alarm output ²⁾ available only for the models TIM M1 / TIM M05

thermoIMAGER TIM NetPC / NetPCQ PC solution for thermoIMAGER TIM applications

TIM NetPC is a professional, embedded industrial PC solution with passive cooling (fanless) for thermoIMAGER applications and is suitable for top hat rail mounting. The NetPC and the TIM camera can be operated in combination as stand-alone system. Remote maintenance via Ethernet is possible. Data provided by the TIM camera can be stored directly on the NetPC where customer-specific software can also be installed. A recovery-stick is included in the scope of delivery.

- Supports all thermoIMAGER TIM models
- Supports 120 Hz (TIM 160), up to 80 Hz (TIM 4x0), up to 32 Hz (TIM 640) frame rates
- Including TIMConnect software
- Monitor via VGA (analog)
- Integrated watchdog feature
- Optional: up to 20 m USB cable, high temperature USB cable, extendable up to 100 m Ethernet cable



thermoIMAGER TIM NetPC

Model	TIM NetPC	TIM NetPCQ
Ambient temperature range	0 °C to 50 °C	
Storage temperature	-20 °C to 60 °C	
Relative humidity	10 to 95 %, non-condensing	
Dimensions	165 x 65 x 130 mm (W x H x D)	
Material (housing)	Anodized aluminum	
Weight	1000 g	
Vibration	IEC-2-6: 3 G, 11 - 200 Hz, each axis	
Shock	IEC-2-27: 50 G, 11 ms, each axis	
Operating system	Windows 7 embedded	
Power supply	12 - 24 V DC	
Power consumption	approx. 9.5 W without TIM [0.76 A with 12 V]	
Cooling	passive cooling (fanless)	
Processor	Intel® Atom™ 2600 @ 2x1.6 GHz Dual	Intel® Atom™ J1900 @ 4x2.4 GHz
Hard drive	integrated 64 GB SSD	
RAM	2 GB DDR3 RAM 800 MHz	
Ports	1 Gbit/s (GigE), 2 x RS 232, 4 x USB 2.0, VGA	1 GigE, 2 x RS232 / 485, 3 x USB 2.0, 1 x USB 3.0, VGA
Additional functions	1x status LED	

thermoIMAGER TIM NetBox

Miniature PC for thermoIMAGER TIM series

- Can be integrated into CoolingJacket Advanced Extended
- Miniature PC for TIM 160/ 4x0 standalone mode for cable extension
- Supports 120 Hz (TIM 160 up to 70 Hz (TIM 4x0) frame rate, 32 Hz (TIM 640)
- Integrated hardware and software watchdog
- Optional: up to 20 m USB cable, high temperature USB cable, extendable up to 100 m Ethernet cable (PoE)



thermoIMAGER TIM NetBox

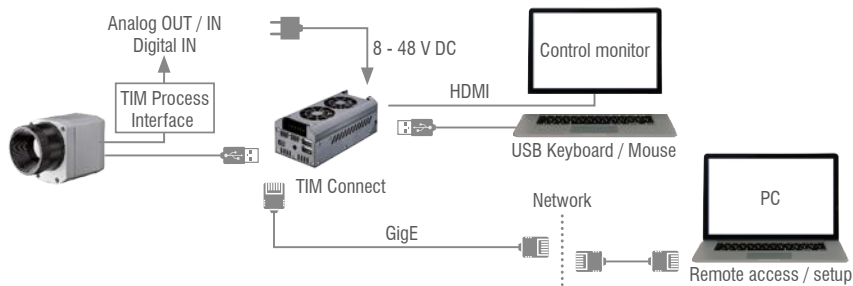

Model	TIM NetBox
Operating temperature	0 °C up to 50 °C
Storage temperature	-20 °C to 75 °C
Relative humidity	10 to 95 %, non-condensing
Material (housing)	Anodized aluminum
Dimensions	113 x 57 x 47 mm
Weight	385 g
Vibration	IEC 60068-2-6 (sinus-shaped) / IEC 60068-2-64 (broadband noise)
Shock	IEC 60068-2-27 (25 g and 50 g)
Operating system	Windows 7 Professional
Power supply	8 ... 48 VDC or Power over Ethernet (PoE/ 1000BASE-T)
Power consumption	7.5 W (+ additional 2.5 W for TIM camera)
Cooling	Active via two integrated fans
Board	COM Express® mini embedded board
Processor	Intel® E3845 Quad Core, 1.91 GHz
Hard drive	16 GB SSD
RAM	2 GB (DDR2, 533MHz)
Ports	2x USB 2.0, 1x USB 3.0, 1x Mini-USB 2.0, Micro-HDMI, Ethernet (Gigabit Ethernet)
Extensions	micro SDHC / SDXC card
Additional functions	4x status LEDs

TIMConnect SOFTWARE FEATURES

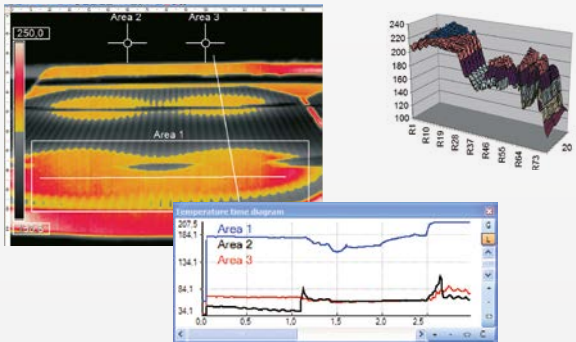

Comprehensive IR camera software

- License-free analysis software and complete SDK included
- Intuitive user interface
- Camera remote control via software
- Displays several camera images in different windows
- Compatible with Windows 7, 8 and 10 and Linux (Ubuntu)
- Data output via PIF hardware interface using up to 3 analog channels



Windows 7



Windows 10



Video recording and snapshot feature (IR or BI-SPECTRAL)

- Recording of video sequences and individual images for later analysis or documentation
- Adjustable frame rate to reduce data volume
- Display of snapshot process for direct analysis

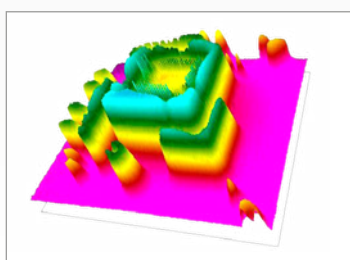
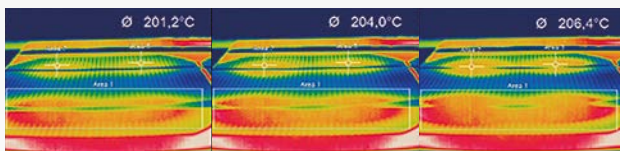

Online and offline data analysis

- Real-time temperature information (°C or °F) in main window, as digital display or graphic display
- Detailed analysis using measuring fields, automatic hotspot/coldspot search
- Logical linking of temperature information
- Slow-motion replay without connected camera
- Various color palettes to highlight thermal contrasts

Temperature data analysis and documentation

- Triggered data collection
- Radiometric video sequences (*.ravi) and snapshots (*.tiff)
- Thermal images as *.tiff or text files *.csv, *.dat incl. complete temperature information
- Data transfer in real time to other software programs via DLL or COM port interfaces

TIM 160 / 200		Focal length [mm]	Angle	Minimum measurement distance*	Distance to measurement object [m]											
160 x 120 px					0.02	0.1	0.2	0.3	0.5	1	2	4	6	10	30	100
23° Standard lens	10	23° 17° 29° 2.48 mrad	0.2 m	HFOV [m]	0.012	0.043	0.08	0.12	0.21	0.41	0.81	1.62	2.44	4.1	12.2	40.6
				VFOV [m]	0.009	0.032	0.06	0.09	0.15	0.30	0.60	1.21	1.81	3.0	9.0	30.1
				DFOV [m]	0.015	0.054	0.10	0.16	0.26	0.51	1.01	2.02	3.03	5.1	15.2	50.5
				IFOV [mm]	0.1	0.3	0.5	0.8	1.3	2.5	5.0	9.9	14.9	24.8	74.4	248.0
6° Telephoto lens	35.5	6° 5° 8° 0.70 mrad	0.5 m	HFOV [m]					0.06	0.11	0.23	0.45	0.68	1.1	3.4	11.3
				VFOV [m]					0.04	0.09	0.17	0.34	0.51	0.8	2.5	8.5
				DFOV [m]					0.07	0.14	0.28	0.57	0.85	1.4	4.2	14.2
				IFOV [mm]					0.4	0.7	1.4	2.8	4.2	7.0	21.1	70.4
48° Wide angle lens	5.7	41° 31° 51° 4.39 mrad	0.2 m	HFOV [m]	0.022	0.082	0.16	0.23	0.38	0.76	1.51	3.00	4.50	7.5	22.5	74.9
				VFOV [m]	0.016	0.059	0.11	0.17	0.28	0.55	1.10	2.19	3.28	5.5	16.4	54.5
				DFOV [m]	0.027	0.101	0.19	0.29	0.47	0.94	1.86	3.72	5.57	9.3	27.8	92.7
				IFOV [mm]	0.1	0.4	0.9	1.3	2.2	4.4	8.8	17.5	26.3	43.9	131.6	438.6
72° Wide angle lens	3.3	72° 52° 89° 7.51 mrad	0.2 m	HFOV [m]	0.039	0.152	0.29	0.43	0.72	1.42	2.84	5.66	8.49	14.1	42.4	141.4
				VFOV [m]	0.027	0.106	0.20	0.30	0.50	0.99	1.98	3.95	5.92	9.9	29.6	98.6
				DFOV [m]	0.048	0.186	0.36	0.53	0.87	1.74	3.46	6.91	10.35	17.2	51.7	172.3
				IFOV [mm]	0.2	0.8	1.5	2.3	3.8	7.5	15.0	30.0	45.0	75.1	225.2	750.8

TIM 400 / 450 / G7		Focal length [mm]	Angle	Minimum measurement distance*	Distance to measurement object [m]											
382 x 288 px					0.02	0.1	0.2	0.3	0.5	1	2	4	6	10	30	100
29° Standard lens	18.7	29° 22° 37° 1.34 mrad	0.2 m	HFOV [m]		0.060	0.11	0.16	0.27	0.53	1.0	2.1	3.1	5.2	15.6	52.1
				VFOV [m]		0.045	0.08	0.12	0.20	0.40	0.78	1.6	2.3	3.9	11.7	39.0
				DFOV [m]		0.074	0.14	0.20	0.33	0.66	1.3	2.6	3.9	6.5	19.5	65.1
				IFOV [mm]		0.1	0.3	0.4	0.7	1.3	2.7	5.4	8.0	13.4	40.1	133.7
13° Telephoto lens (except for G7)	41	13° 10° 17° 0.61 mrad	0.5 m	HFOV [m]					0.12	0.23	0.47	0.94	1.40	2.3	7.0	23.4
				VFOV [m]					0.09	0.17	0.35	0.70	1.05	1.7	5.2	17.5
				DFOV [m]					0.15	0.29	0.58	1.17	1.75	2.9	8.8	29.2
				IFOV [mm]					0.3	0.6	1.2	2.5	3.7	6.1	18.4	61.2
53° Wide angle lens	10.5	53° 40° 66° 2.38 mrad	0.2 m	HFOV [m]		0.11	0.21	0.31	0.51	1.0	2.0	4.0	6.0	9.9	29.7	99.0
				VFOV [m]		0.08	0.15	0.23	0.37	0.73	1.4	2.9	4.3	7.2	21.6	71.9
				DFOV [m]		0.14	0.26	0.38	0.63	1.2	2.5	4.9	7.4	12.2	36.7	122.3
				IFOV [mm]		0.2	0.5	0.7	1.2	2.4	4.8	9.5	14.3	23.8	71.5	238.4
80° Wide angle lens	7.7	80° 56° 97° 3.25 mrad	0.2 m	HFOV [m]		0.182	0.35	0.84	0.84	1.65	3.29	6.55	9.82	16.4	49.0	163.4
				VFOV [m]		0.119	0.23	0.55	0.54	1.08	2.14	4.28	6.41	10.7	32.0	106.6
				DFOV [m]		0.218	0.41	1.00	1.00	1.97	3.92	7.83	11.73	19.5	58.5	195.1
				IFOV [mm]		0.3	0.7	1.6	1.6	3.3	6.5	13.0	19.5	32.5	97.4	324.7

TIM 640 640 x 480 px	Focal length [mm]	Angle	Minimum measurement distance*	Distance to measurement object [m]											
					0.1	0.2	0.3	0.5	1	2	4	6	10	30	100
33° Standard lens	18.7	33° 25° 41° 0.91 mrad	0.2 m	HFOV [m]	0.068	0.13	0.19	0.31	0.60	1.20	2.38	3.57	5.9	17.8	59.3
				VFOV [m]	0.051	0.09	0.14	0.23	0.45	0.89	1.77	2.65	4.4	13.2	44.2
				DFOV [m]	0.085	0.16	0.23	0.38	0.75	1.49	2.97	4.45	7.4	22.2	74.0
				IFOV [mm]	0.1	0.2	0.3	0.5	0.9	1.8	3.6	5.5	9.1	27.3	90.9
15° Telephoto lens	41.5	15° 11° 19° 0.41 mrad	0.5 m	HFOV [m]				0.13	0.26	0.52	1.05	1.57	2.6	7.8	26.1
				VFOV [m]				0.10	0.20	0.39	0.79	1.18	2.0	5.9	19.6
				DFOV [m]				0.17	0.33	0.66	1.31	1.96	3.3	9.8	32.7
				IFOV [mm]				0.2	0.4	0.8	1.6	2.5	4.1	12.3	41.0
60° Wide angle lens	10.5	60° 45° 75° 1.62 mrad	0.2 m	HFOV [m]	0.128	0.25	0.36	0.59	1.17	2.32	4.63	6.94	11.6	34.6	115.4
				VFOV [m]	0.091	0.18	0.26	0.42	0.83	1.66	3.31	4.96	8.3	24.7	82.4
				DFOV [m]	0.157	0.30	0.44	0.72	1.43	2.85	5.69	8.52	14.2	42.6	141.8
				IFOV [mm]	0.2	0.3	0.5	0.8	1.6	3.2	6.5	9.7	16.2	48.6	161.9
90° Super wide angle lens	7.7	90° 64° 111° 2.21 mrad	0.2 m	HFOV [m]	0.220	0.43	0.63	1.03	2.03	4.04	8.06	12.07	20.1	60.3	200.8
				VFOV [m]	0.138	0.27	0.39	0.64	1.27	2.53	5.05	7.57	12.6	37.8	125.9
				DFOV [m]	0.260	0.50	0.73	1.21	2.39	4.76	9.50	14.24	23.7	71.1	237.0
				IFOV [mm]	0.2	0.4	0.7	1.1	2.2	4.4	8.8	13.2	22.1	66.2	220.8

FOV = Field of view; HFOV = Horizontal field of view; VFOV = Vertical field of view; DFOV = Diagonal dimension of the total measuring field at the object level; IFOV = Indicated field of view
Table with examples showing which measuring field sizes and pixel sizes are reached at which distance. Various lenses are available for optimal configuration of the camera.
Wide angle lenses have radial distortion due to the angle of their aperture. The TIMConnect software has an algorithm which corrects this distortion.

* Please note: The measurement accuracy of the camera may lie outside of the specifications for distances below the defined minimum measurement distance.

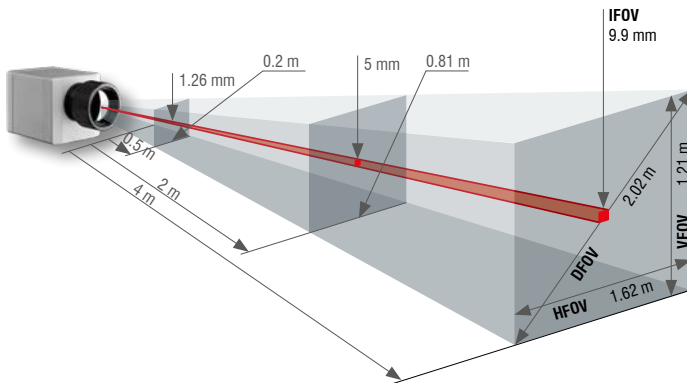

- Standard-, telephoto- and wide angle lenses for adaptation to different applications
- High quality germanium lenses and special anti-reflective coating for excellent optics
- Factory-calibrated lenses for easy exchange of optical system without recalibration

Measuring field sizes can be calculated online at www.micro-epsilon.com/optikkalkulator.

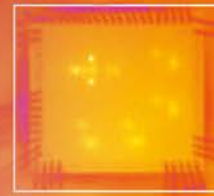

TIM M1 / TIM M05 ¹⁾	Focal length [mm]	Angle	Minimum measurement distance*	Distance to measurement object [m]												
					0.1	0.2	0.3	0.5	1	2	4	6	10	30	100	
382 x 288 px																
f=16 mm wide angle lens	16	20° 15° 25° 0.94 mrad	0.2 m	HFOV [m] VFOV [m] DFOV [m] IFOV [mm]		0.07 0.05 0.09 0.2	0.11 0.08 0.13 0.3	0.18 0.14 0.22 0.5	0.36 0.27 0.45 0.9	0.72 0.54 0.90 1.9	1.43 1.08 1.79 3.8	2.15 1.62 2.69 5.6	3.6 2.7 4.5 9.4	10.7 8.1 13.5 28.1	35.8 27.0 44.9 93.8	
f=25 mm standard lens	25	13° 10° 16° 0.60 mrad	0.5 m	HFOV [m] VFOV [m] DFOV [m] IFOV [mm]	0.023 0.017 0.029 0.1	0.05 0.03 0.06 0.1	0.07 0.05 0.09 0.2	0.11 0.09 0.14 0.3	0.23 0.17 0.29 0.6	0.46 0.35 0.57 1.2	0.92 0.69 1.15 2.4	1.38 1.04 1.72 3.6	2.3 1.7 2.9 6.0	6.9 5.2 8.6 18.0	22.9 17.3 28.7 60.0	
f=50 mm telephoto lens	50	7° 5° 8° 0.30 mrad	1.5 m	HFOV [m] VFOV [m] DFOV [m] IFOV [mm]				0.06 0.04 0.07 0.2	0.11 0.09 0.14 0.3	0.23 0.17 0.29 0.6	0.46 0.35 0.57 1.2	0.69 0.52 0.86 1.8	1.1 0.9 1.4 3.0	3.4 2.6 4.3 9.0	11.5 8.6 14.4 30.0	
f=75 mm Super telephoto lens	75	4° 3° 5° 0.20 mrad	2.0 m	HFOV [m] VFOV [m] DFOV [m] IFOV [mm]					0.08 0.06 0.10 0.2	0.15 0.12 0.19 0.4	0.31 0.23 0.38 0.8	0.46 0.35 0.57 1.2	0.8 0.6 1.0 2.0	2.3 1.7 2.9 6.0	7.6 5.8 9.6 20.0	

¹⁾ TIM M05 only available with OF25 lens | Please note: the camera provides 382 x 288 px in the 80 Hz mode

TIM M1 / M05 with VGA ¹⁾ Resolution	Focal length [mm]	Angle	Minimum measurement distance*	Distance to measurement object [m]												
					0.1	0.2	0.3	0.5	1	2	4	6	10	30	100	
764 x 480 px																
f=16 mm wide angle lens	16	39° 25° 46° 0.94 mrad	0.2 m	HFOV [m] VFOV [m] DFOV [m] IFOV [mm]		0.14 0.09 0.17 0.2	0.21 0.14 0.25 0.3	0.36 0.23 0.42 0.5	0.72 0.45 0.85 0.9	1.43 0.90 1.69 1.9	2.87 1.80 3.38 3.8	4.30 2.70 5.08 5.6	7.2 4.5 8.5 9.4	21.5 13.5 25.4 28.1	71.6 45.0 84.6 93.8	
f=25 mm standard lens	25	26° 16° 30° 0.60 mrad	0.5 m	HFOV [m] VFOV [m] DFOV [m] IFOV [mm]	0.046 0.029 0.054 0.1	0.09 0.06 0.11 0.1	0.14 0.09 0.16 0.2	0.23 0.14 0.27 0.3	0.46 0.29 0.54 0.6	0.92 0.58 1.08 1.2	1.83 1.15 2.17 2.4	2.75 1.73 3.25 3.6	4.6 2.9 5.4 6.0	13.8 8.6 16.2 18.0	45.8 28.8 54.1 60.0	
f=50 mm telephoto lens	50	13° 8° 15° 0.30 mrad	1.5 m	HFOV [m] VFOV [m] DFOV [m] IFOV [mm]				0.11 0.07 0.14 0.2	0.23 0.14 0.27 0.3	0.46 0.29 0.54 0.6	0.92 0.58 1.08 1.2	1.38 0.86 1.62 1.8	2.3 1.4 2.7 3.0	6.9 4.3 8.1 9.0	22.9 14.4 27.1 30.0	
f=75 mm Super telephoto lens	75	9° 5° 10° 0.20 mrad	2.0 m	HFOV [m] VFOV [m] DFOV [m] IFOV [mm]					0.15 0.10 0.18 0.2	0.31 0.19 0.36 0.4	0.61 0.38 0.72 0.8	0.92 0.58 1.08 1.2	1.5 1.0 1.8 2.0	4.6 2.9 5.4 6.0	15.3 9.6 18.0 20.0	

¹⁾ TIM M05 is only available with OF25 lens | Please note: the camera provides 764 x 480 px in the 32 Hz mode

High performance sensors made by Micro-Epsilon



Sensors and systems for displacement and position



Sensors and measurement devices for non-contact temperature measurement



2D/3D profile sensors (laser scanner)



Optical micrometers, fiber optic sensors and fiber optics



Color recognition sensors, LED analyzers and color inline spectrometer



Measurement and inspection systems