



# More Precision.

indu**SENSOR** // Linear inductive displacement sensors





	<b>Measuring ranges</b> from 75 ... 630 mm
	<b>Linearity</b> $\pm 0.3\%$ FSO
	<b>Integrated controller</b>
	<b>High resistance to pressure and oil, maintenance free</b>
	<b>Short offset ranges</b>

induSENSOR EDS long-stroke sensors are designed for industrial use in hydraulic and pneumatic cylinders for displacement and position measurements of pistons or valves, e.g., to measure

- displacement, position, gap
- deflection
- movement, stroke
- filling level, immersion depth and spring travel

The sensor elements of the EDS series are protected by a pressure resistant stainless steel housing. The sensor controller and signal processing are completely integrated in a sensor flange.

An aluminum tube is used as target, which is guided over the sensor rod in a non-contact and wear-free manner.

Due to their robust, constructional design, the EDS long-stroke sensors have proven invaluable for integration into hydraulic and pneumatic cylinders and for position monitoring in harsh industrial environments. Due to the eddy current principle applied, no permanent magnets need to be mounted inside the cylinder.

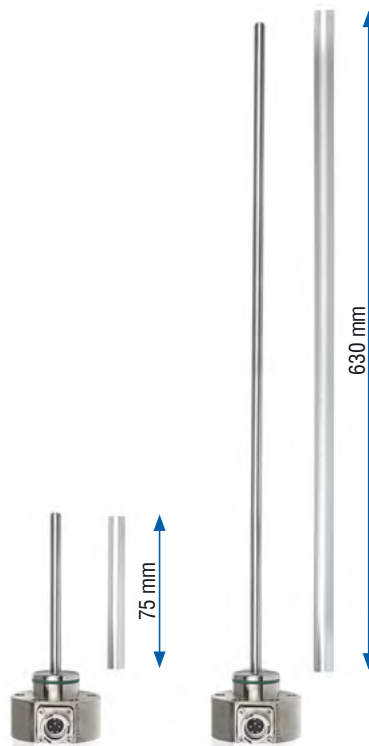

induSENSOR EDS sensors impress with an optimal ratio of compact design and large measuring range. Due to their small offset, the measuring range starts very close to the flange.



Model	EDS-75	EDS-100	EDS-160	EDS-200	EDS-250	EDS-300	EDS-400	EDS-500	EDS-630
Series	S	S, F	S, F	S	S, F	S, F	S, F	S	S, F
Measuring range	75 mm	100 mm	160 mm	200 mm	250 mm	300 mm	400 mm	500 mm	630 mm
Resolution	0.038 mm	0.05 mm	0.08 mm	0.1 mm	0.125 mm	0.15 mm	0.2 mm	0.25 mm	0.315 mm
Frequency response (-3dB)	150 Hz								
Measuring rate	600 Sa/s								500 Sa/s
Linearity $\leq \pm 0.3\%$ FSO	$\leq \pm 0.23$ mm	$\leq \pm 0.3$ mm	$\leq \pm 0.48$ mm	$\leq \pm 0.6$ mm	$\leq \pm 0.75$ mm	$\leq \pm 0.9$ mm	$\leq \pm 1.2$ mm	$\leq \pm 1.5$ mm	$\leq \pm 1.89$ mm
Temperature stability	$\leq 200$ ppm FSO/K								
Supply voltage	18 ... 30 VDC								
Max. current consumption	40 mA								
Analog output <sup>1)</sup>	4 ... 20 mA (load 500 Ohm)								
Connection	S Series	7-pin M9 screw/plug connection (Binder); axial, radial on request (see accessories for connection cable)							
	F series	Bayonet 5-pin screw/plug connection; radial output (see accessories for connection cable)							
Temperature range	Storage	-40 ... +100 °C							
	Operation	-40 ... +85 °C							
Pressure resistance	450 bar (front)								
Shock (DIN EN 60068-2-27)	40 g / 6 ms in 3 axes, 1000 shocks each 100 g / 6 ms radial, 3 shocks each 300 g / 6 ms axial, 3 shocks each								
Vibration (DIN EN 60068-2-6)	$\pm 2.5$ mm / 5 ... 44 Hz, 10 cycles each $\pm 23$ g / 44 ... 500 Hz, 10 cycles each								
Protection class (DIN EN 60529) <sup>2)</sup>	IP65 (F series) / IP67 (S series)								
Material	Stainless steel (housing); aluminum (measuring tube)								

FSO = Full Scale Output

<sup>1)</sup> Optional voltage output (1 ... 5 V) with output cable C703-5/U for EDS, S series

<sup>2)</sup> Models with plug connection only with suitable and connected mating plug

**Model S**

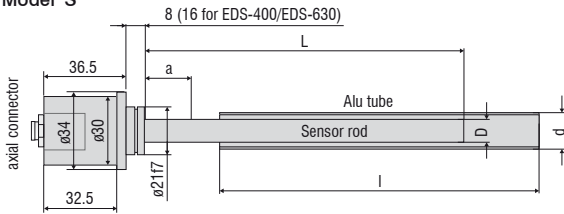

**Model F**

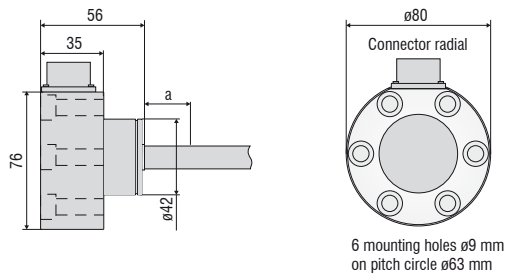

**Article designation**

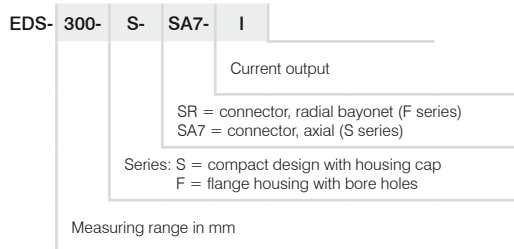

Measuring ranges	Sensor rod		Aluminum tube		Offset
	L	D	l	d	
75	110	10	110	16	15
100	140	10	140	16	20
160	200	10	200	16	20
200	240	10	240	16	20
250	290	10	290	16	20
300	340	10	340	16	20
400	450	12	450 (S) 460 (F)	18 (S) 26 (F)	25
500	550	12	550	18	25
630	680	12	680 (S) 690 (F)	18 (S) 26 (F)	25

## Accessories for S series

### Connection cables

- C703-5 EDS connection cable for S series, 7-pin, length 5 m  
 C703-5/U EDS connection cable for S series, 7-pin, length 5 m, for voltage output 1 - 5 V  
 C703/90-5 EDS connection cable for S series, 7-pin, length 5 m with 90° angled cable connector

### Spare tubes

- Measuring tube for EDS-75-S Spare tube  
 Measuring tube for EDS-100-S Spare tube  
 Measuring tube for EDS-160-S Spare tube  
 Measuring tube for EDS-200-S Spare tube  
 Measuring tube for EDS-250-S Spare tube  
 Measuring tube for EDS-300-S Spare tube  
 Measuring tube for EDS-400-F Spare tube  
 Measuring tube for EDS-630-F Spare tube

### Installation ring

- 0483326 EDS mounting ring

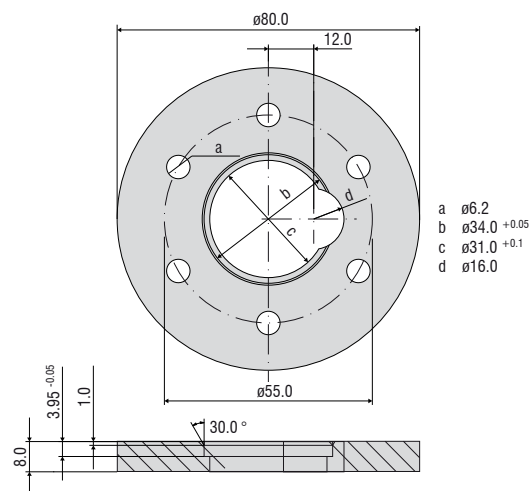

## Accessories for the F series

### Connection cables

- C705-5 EDS connection cable for F series, 5-pin, length 5 m  
 C705-15 EDS connection cable for F series, 5-pin, length 15 m

Mating plug, S series

EDS connector kit, F series

### Spare tubes

- Measuring tube for EDS-100-F Spare tube  
 Measuring tube for EDS-160-F Spare tube  
 Measuring tube for EDS-200-F Spare tube  
 Measuring tube for EDS-250-F Spare tube  
 Measuring tube for EDS-300-F Spare tube  
 Measuring tube for EDS-400-F Spare tube  
 Measuring tube for EDS-630-F Spare tube



EDS-F: Measuring the grinding gap in crushers



EDS-S: Lift height measurement in pneumatic cylinders; flange outside the cylinder



EDS-Z: Integration in hydraulic cylinders; integrated flange and M12 built-in plug

## Sensors and Systems from Micro-Epsilon



Sensors and systems for displacement, distance and position



Sensors and measurement devices for non-contact temperature measurement



Measuring and inspection systems for metal strips, plastics and rubber



Optical micrometers and fiber optics, measuring and test amplifiers



Color recognition sensors, LED analyzers and inline color spectrometers

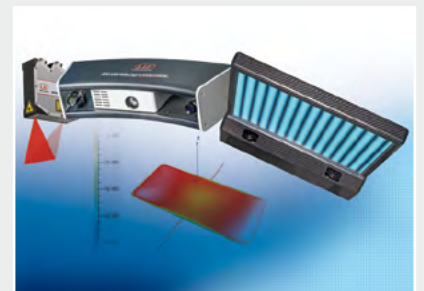

3D measurement technology for dimensional testing and surface inspection