



# More Precision

thermo**IMAGER** TIM // Compact thermal imaging cameras





### thermoIMAGER TIM QVGA-G7 / VGA-G7

Thermal imaging camera with line scan feature for the glass industry

- Line scan feature via license-free TIMConnect analysis software
- Frame rate up to 125 Hz
- Robust against ambient temperatures up to 70 °C without requiring additional cooling, up to 315 °C with Cooling Jacket Advanced
- Optional integration of a reference pyrometer for glass with a reflection coating
- Compact design (46 mm x 56 mm x 68 - 100 mm) with USB interface
- Lightweight (237 - 340 g, incl. lens)
- Exchangeable lenses & industrial accessories
- TIMConnect software delivered with Software Developer Kit

### Software

- Line scan feature
- Display of the thermal image in real time (80 Hz) with recording function (video, snapshot)
- Complete set up of parameters and remote control of the camera
- Detailed analysis of fast, thermodynamic processes
- Output of analog temperature or alarm values via the process interface
- Digital communication via RS232 or DLL for software integration

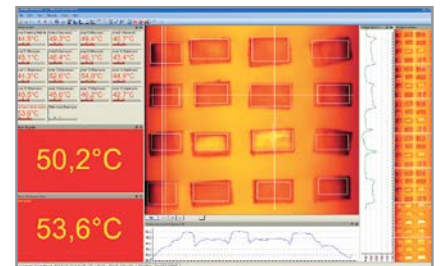

Exact temperature measurement on moving glass surfaces due to line scan feature

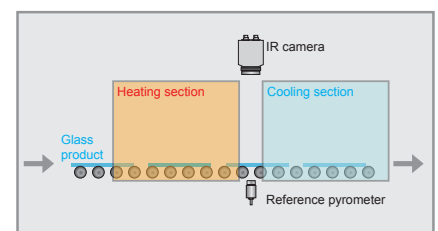

Line scan camera feature measures the temperature distribution between the heating zone and the cooling zone e.g. when toughened or tempered safety glass is heat-treated.

### thermoIMAGER TIM QVGA-G7

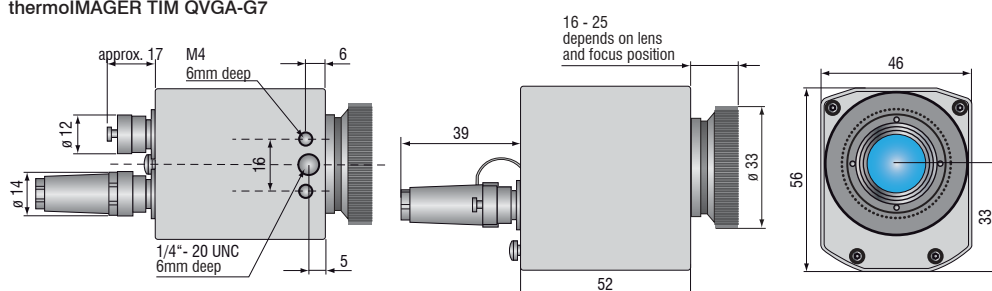

Model	TIM QVGA-G7	TIM VGA-G7
Optical resolution	382 x 288 pixels	640 x 480 pixels
Temperature ranges	150 ... 900 °C, 200 ... 1500 °C (sighting range without measurement: 0 ... 250 °C)	
Spectral range	7.9 μm	
Frame rate	switchable 80 Hz or 27 Hz	32 Hz / 125 Hz in the subframe mode (640 x 120 pixels)
System accuracy	±2 °C or ±2 %, whichever is greater	
Lenses	18° x 14° FOV / f = 20 mm or 29° x 22° FOV / f = 12.7 mm or 53° x 38° FOV / f = 7.7 mm or 80° x 54° FOV / f = 5.7 mm	15° x 11° FOV / f = 41.5 mm or 33° x 25° FOV / f = 18.7 mm or 60° x 45° FOV / f = 10.5 mm or 90° x 64° FOV / f = 7.7 mm
Thermal sensitivity (NETD)	150 mK ( $T_{obj} = 650 °C / 20 Hz$ ) 175 mK for 18° lens ( $T_{obj} = 650 °C / 20 Hz$ )	130 mK ( $T_{obj} = 650 °C / 20 Hz$ ) 150 mK for 15° lens ( $T_{obj} = 650 °C / 20 Hz$ )
Detector	FPA, uncooled (17 μm x 17 μm)	
Outputs/digital	USB 2.0 / optional interface USB to GigE (PoE)	
Standard process interface (PIF)	0 - 10 V input, digital input (max. 24 V), 0 - 10 V output	
Industry process interface (PIF)	2x 0 - 10 V inputs, digital input (max. 24 V), 3x 0/4 - 20 mA outputs, 3x relays (0 - 30 V/ 400 mA), fail-safe relay	
Cable length (USB)	1 m (standard), 5 m, 10 m 5 m and 10 m also available as high temperature USB cable (180° C or 250 °C)	
Power supply	USB powered	
Tripod mount	1/4-20 UNC	
Protection class	IP67	
Ambient temperature	0 ... 70 °C	0 ... 50 °C
Storage temperature	-40 ... 85 °C	-40 ... 85 °C
Relative humidity	20 to 80 %, non-condensing	
Vibration	IEC 60068-2-6 (sinus-shaped) / IEC 60068-2-64 (broadband noise)	
Shock	IEC 60068-2-27 (25 g and 50 g)	
Housing (size)	46 mm x 56 mm x 68 - 77 mm <sup>1)</sup>	46 mm x 56 mm x 76 - 100 mm <sup>1)</sup>
Weight	237 - 251 g	269 - 340 g

<sup>1)</sup> Depending on lens and focus position

#### thermoIMAGER TIM VGA-G7

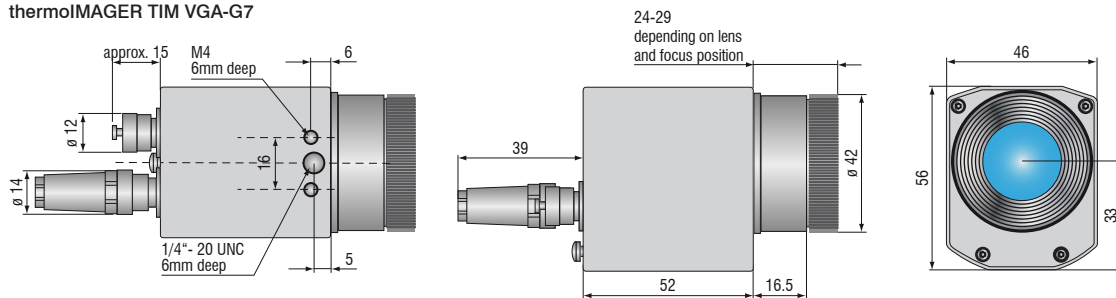

#### Scope of supply

##### TIM QVGA-G7 / VGA-G7

- TIM process camera  
incl. a selectable lens
- Operating instructions
- USB cable 1 m
- Software for real-time processing  
and analyzing thermal images
- Tripod mount
- PIF cable incl. terminal block (1 m)
- Transport case
- Test certificate

## TIMConnect SOFTWARE FEATURES

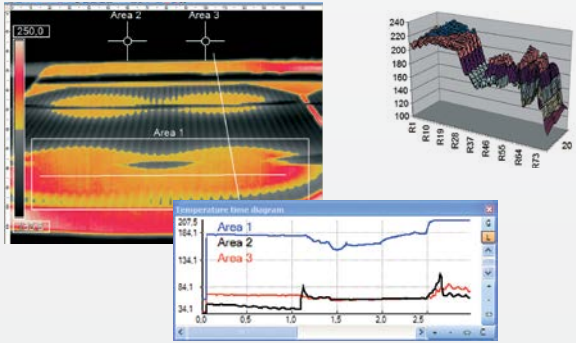

### Comprehensive IR camera software

- License-free analysis software and complete SDK included
- Intuitive user interface
- Camera remote control via software
- Displays several camera images in different windows
- Compatible with Windows 7, 8 and 10
- Data output via PIF hardware interface using up to 3 analog channels

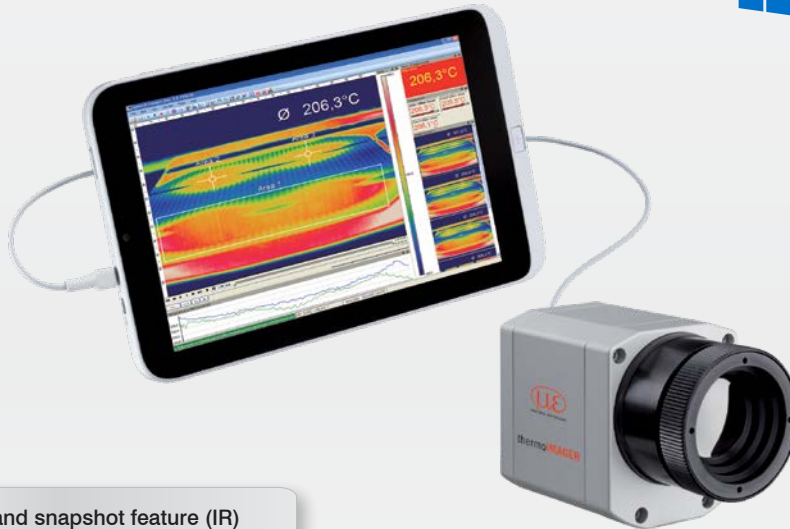

### Video recording and snapshot feature (IR)

- Recording of video sequences and individual images for later analysis or documentation
- Adjustable frame rate to reduce data volume
- Display of snapshot process for direct analysis

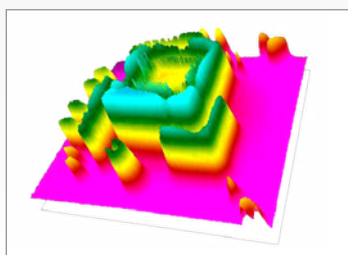
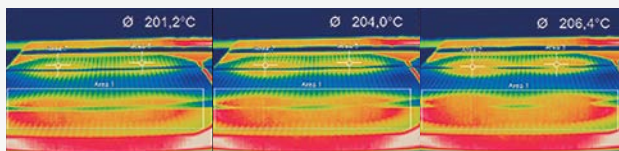

### Online and offline data analysis

- Real-time temperature information (°C or °F) in main window, as digital display or graphic display
- Detailed analysis using measuring fields, automatic hotspot/coldspot search
- Logical linking of temperature information
- Slow-motion replay without connected camera
- Various layout functions and color palettes to highlight thermal contrasts

### Temperature data analysis and documentation

- Triggered data collection
- Radiometric video sequences (\*.ravi) and snapshots (\*.tiff)
- Thermal images as \*.tiff or \*.csv, \*.dat text files incl. complete temperature information
- Data transfer in real time to other software programs via DLL or COM port interfaces

Lenses thermoIMAGER TIM 640 VGA / TIM VGA-G7

TIM 640 VGA / TIM VGA-G7	Focal length [mm]	Angle	Minimum measurement distance*	Distance to measurement object [m]													
					0.1	0.2	0.3	0.5	1	2	4	6	10	30	100		
640 x 480 px																	
33° Standard lens	18.7	33° 25° 41° 0.91 mrad	0.2 m	HFOV [m]	0.068	0.13	0.19	0.31	0.60	1.20	2.38	3.57	5.9	17.8	59.3		
				VFOV [m]	0.051	0.09	0.14	0.23	0.45	0.89	1.77	2.65	4.4	13.2	44.2		
				DFOV [m]	0.085	0.16	0.23	0.38	0.75	1.49	2.97	4.45	7.4	22.2	74.0		
				IFOV [mm]	0.1	0.2	0.3	0.5	0.9	1.8	3.6	5.5	9.1	27.3	90.9		
15° Telephoto lens	41.5	15° 11° 19° 0.41 mrad	0.5 m	HFOV [m]				0.13	0.26	0.52	1.05	1.57	2.6	7.8	26.1		
				VFOV [m]				0.10	0.20	0.39	0.79	1.18	2.0	5.9	19.6		
				DFOV [m]				0.17	0.33	0.66	1.31	1.96	3.3	9.8	32.7		
				IFOV [mm]				0.2	0.4	0.8	1.6	2.5	4.1	12.3	41.0		
60° Wide angle lens	10.5	60° 45° 75° 1.62 mrad	0.2 m	HFOV [m]	0.128	0.25	0.36	0.59	1.17	2.32	4.63	6.94	11.6	34.6	115.4		
				VFOV [m]	0.091	0.18	0.26	0.42	0.83	1.66	3.31	4.96	8.3	24.7	82.4		
				DFOV [m]	0.157	0.30	0.44	0.72	1.43	2.85	5.69	8.52	14.2	42.6	141.8		
				IFOV [mm]	0.2	0.3	0.5	0.8	1.6	3.2	6.5	9.7	16.2	48.6	161.9		
90° Super wide angle lens	7.7	90° 64° 111° 2.21 mrad	0.2 m	HFOV [m]	0.220	0.43	0.63	1.03	2.03	4.04	8.06	12.07	20.1	60.3	200.8		
				VFOV [m]	0.138	0.27	0.39	0.64	1.27	2.53	5.05	7.57	12.6	37.8	125.9		
				DFOV [m]	0.260	0.50	0.73	1.21	2.39	4.76	9.50	14.24	23.7	71.1	237.0		
				IFOV [mm]	0.2	0.4	0.7	1.1	2.2	4.4	8.8	13.2	22.1	66.2	220.8		

FOV = Field of view; HFOV = Horizontal field of view; VFOV = Vertical field of view; DFOV = Diagonal dimension of the total measuring field at the object level; IFOV = Indicated field of view  
 Table with examples showing which measuring field sizes and pixel sizes are reached at which distance. Various lenses are available for optimal configuration of the camera.  
 Wide angle lenses have radial distortion due to the angle of their aperture. The TIMConnect software has an algorithm which corrects this distortion.

\* Please note: The measurement accuracy of the camera may lie outside of the specifications for distances below the defined minimum measurement distance.

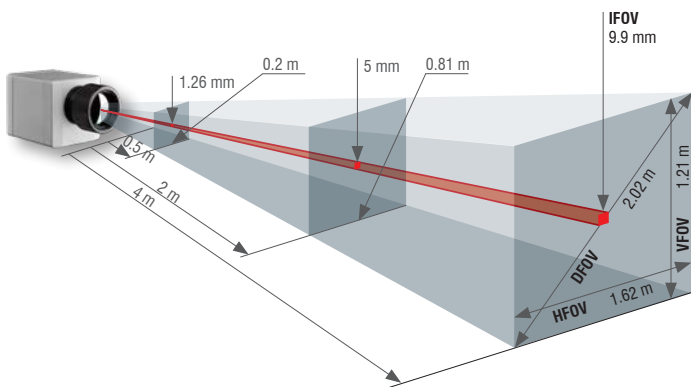

- Standard-, telephoto- and wide angle lenses for optimal adaptation to different applications
- High quality germanium lenses and special anti-reflective coating for excellent optics
- Factory-calibrated lenses for easy exchange of optical system without recalibration

Measuring field sizes can be calculated online at [www.micro-epsilon.com/optikkalkulator](http://www.micro-epsilon.com/optikkalkulator).

## Sensors and Systems from Micro-Epsilon

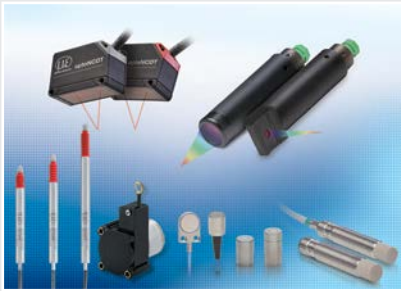

Sensors and systems for displacement, distance and position



Sensors and measurement devices for non-contact temperature measurement



Measuring and inspection systems for metal strips, plastics and rubber

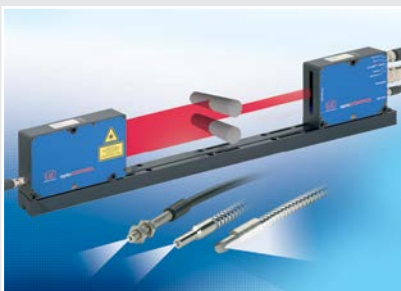

Optical micrometers and fiber optics, measuring and test amplifiers



Color recognition sensors, LED analyzers and inline color spectrometers

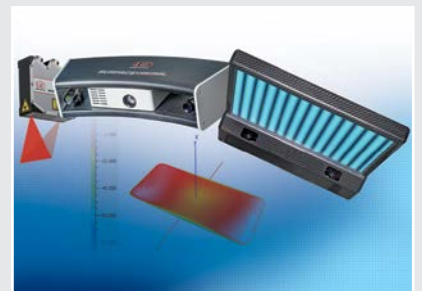

3D measurement technology for dimensional testing and surface inspection