



Operating Instructions
surfaceCONTROL 3D 35xx

SC3500-80
SC3510-80
SC3500-120
SC3510-120

MICRO-EPSILON
MESSTECHNIK
GmbH & Co. KG
Koenigbacher Str. 15

94496 Ortenburg / Germany

Tel. +49 (0) 8542 / 168-0
Fax +49 (0) 8542 / 168-90
e-mail info@micro-epsilon.com
www.micro-epsilon.com

Contents

1.	Safety	5
1.1	Symbols Used	5
1.2	Warnings	5
1.3	Notes on CE Marking	6
1.4	Intended Use	6
1.5	Proper Environment.....	6
2.	Light Source	7
3.	Functional Principle, Technical Data	8
3.1	Short Description	8
3.1.1	Measuring Principle.....	8
3.1.2	System Setup	8
3.1.3	Special Performance Features	8
3.2	Technical Data	9
3.3	LED Displays.....	10
4.	Delivery	11
4.1	Unpacking, Included in Delivery.....	11
4.2	Storage	11
5.	Installation and Mounting	12
5.1	Attachment and Mounting	12
5.2	Electrical Connections.....	16
5.2.1	General	16
5.2.2	Supply Voltage (Power).....	16
5.2.3	Gigabit Ethernet Connection.....	17
5.2.4	Multi-Function Connection I/O	18
5.2.4.1	Digital Signals	18
5.2.4.2	Electrical Parameters of Digital Inputs, Multi-Function Connection.....	19
5.2.4.3	Electrical Parameters of Digital Outputs, Multi-Function Connection.....	20
5.3	Installation Instructions	20
5.4	Commissioning.....	20
6.	Operation	21
6.1	Turning On	21
6.2	Operating Programs	21
6.3	Installation.....	21
6.3.1	Requirements	21
6.3.2	Connecting surfaceCONTROL 3D 35xx to the PC.....	21
6.4	Notes for Operation	22
6.4.1	Measuring Range	22
6.4.2	Calibration	22
6.4.3	Positioning of Sensor and Test Object	23
6.4.3.1	General.....	23
6.4.3.2	Alignment with Crosshair.....	23
6.4.4	Exposure.....	25
6.5	Temperature	25
6.6	Error Influences.....	26
6.6.1	Reflection Factor of the Surface of the Target.....	26
6.6.2	Color Differences	26
6.6.3	Temperature Influences.....	26
6.6.4	External Light.....	26
6.6.5	Mechanical Vibrations	26
6.6.6	Surface Roughness and Texture	26
6.6.7	Shadowing Effects and Multiple Reflections.....	27
6.7	Cleaning.....	27
7.	Liability for Material Defects	28
8.	Service, Repair	28
9.	Decommissioning, Disposal	28
	Appendix	29
A 1	Accessories	29
A 2	Optional Accessories	29
A 3	Genicam surfaceCONTROL Parameters	31

1. Safety

The handling of the sensor assumes knowledge of the operating instructions.

1.1 Symbols Used

The following symbols are used in this operating instructions:



Indicates a hazardous situation which, if not avoided, may result in minor or moderate injury.



Indicates a situation that may result in property damage if not avoided.



Indicates a user action.



Indicates a tip for users.

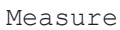

Indicates hardware or a software button/menu.

1.2 Warnings



Do not look directly into the light source of the sensor.

> Risk of injury, damage to the eyes and skin

Connect the power supply and the display/output device according to the safety regulations for electrical equipment.

> Risk of injury

> Damage to or destruction of the sensor



Avoid shocks and impacts to the sensor.

> Damage to or destruction of the sensor

The supply voltage must not exceed the specified limits.

> Damage to or destruction of the sensor

Avoid constant exposure of the sensor to dust or splashes of water by appropriate methods such as blowing or using a protective housing.

> Damage to or destruction of the sensor

Do not touch the protective windows of the optics. Wipe off any fingerprints immediately with pure alcohol and a clean cotton cloth with no streaks.

> Failure of the measuring device

Protect the cables against damage.

> Failure of the measuring device

The sensor housing may only be opened by authorized persons.

> Damage to or destruction of the sensor

Do not plug or unplug devices during the operation.

1.3 Notes on CE Marking

The following apply to the surfaceCONTROL 3D 35xx:

- EU Directive 2014/30/EU
- EU Directive 2011/65/EU

Products which carry the CE mark satisfy the requirements of the EU directives cited and the relevant applicable harmonized European standards (EN). The measuring system is designed for use in industrial environments.

The EU Declaration of Conformity and the technical documentation are available to the responsible authorities according to the EU Directives.

1.4 Intended Use

- The surfaceCONTROL 3D 35xx measuring system is designed for use in industrial applications.
 - Non-contact optical measurement of diffuse reflective surfaces
 - Quality monitoring as well as form/position and surface inspection
- The system must only be operated within the limits specified in the technical data, see Chap. 3.2.
- The sensor must be used in such a way that no persons are endangered or machines and other material goods are damaged in the event of malfunction or total failure of the sensor.
- Take additional precautions for safety and damage prevention in case of safety-related applications.

1.5 Proper Environment

- Protection class
 - Sensor: IP67 (only applies in the case of connected output connectors and/or installed protective caps)

Optical paths during operation are excluded from the protection class.

Contamination of the paths causes impairment or failure of the function.

The IP67 protection class is a specification that is limited to protection from dust and water. Oil, steam and emulsion effects are not included in this protection class and must be evaluated separately.

- Temperature range
 - Operation: 0 ... +45 °C ¹ (+32 ... +113 °F) (with appropriate heat dissipation)
 - Storage: -20 ... +70 °C (-4 ... +158 °F)
- Humidity: 20 ... 80 % (non condensing)
- Ambient pressure: Atmospheric pressure

1) Max. permissible operating temperature depends on installation scenario, thermal connection and operating mode. If necessary, external heat dissipation must be used to ensure that the sensor's internal temperature of 60 °C is not exceeded.

2. Light Source

The surfaceCONTROL 3D 35xx sensor works with an LED lighting unit. Measurement is performed using blue light at the dominant 459 nm wavelength. The sensor is included in risk group 2 according to EN 62471: 2008.



Do not look into the lens. Consciously close your eyes or immediately turn away if the optical radiation enters the eye.

The warning sign below is attached to the sensor housing on the top and bottom:



Fig. 1 LED warning sign

- i** If both warning labels are covered over when the unit is installed, the user must ensure that supplementary labels are applied.

3. Functional Principle, Technical Data

3.1 Short Description

3.1.1 Measuring Principle

surfaceCONTROL 3D 35xx is a sensor for non-contact and non-destructive optical and three-dimensional detection of components with diffuse reflective surfaces. It operates according to the optical triangulation principle (fringe projection):

- Using a matrix projector, a sequence of patterns is projected onto the surface of the test object.
- The light of the patterns diffusely reflected by the test object surface is recorded by two cameras.
- The three-dimensional surface of the test object is then calculated from the recorded image sequence and the arrangement of the two cameras to each other.

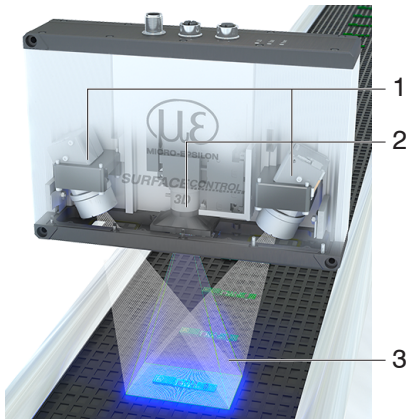

- 1 Cameras
- 2 Projection unit
- 3 Fringe light

Fig. 2 Measuring Principle

3.1.2 System Setup

The surfaceCONTROL 3D 35xx measuring system is a compact sensor with an integrated controller. All necessary integral parts are combined in one housing.

3.1.3 Special Performance Features

- surfaceCONTROL 3D 35xx is characterized by a compact design and highly accurate measurements while at the same time achieving high throughput of 3D points.
- Data are output via Gigabit Ethernet. GigE Vision compatibility allows the sensor to be integrated in different ways:
 - Software provided by Micro-Epsilon
 - Software by third parties
 - SDK
- Gigabit Ethernet as a fast default connection to the PC
- The sensor additionally offers an I/O interface:
 - Querying sensor states
 - External control, e.g., triggering

System integrators	
<p>SC3500</p> 	<ul style="list-style-type: none"> - supported by 3D-View - supported by 3DInspect - supported by SDK - supports GigE Vision - supported by DefMap3D (licensing via additional dongle)
Customers require their own software	

User	
<p>SC3510</p> 	<ul style="list-style-type: none"> - unlocking of functional extension 3DInspect Automation
Micro-Epsilon software	

3.2 Technical Data

Model		SC3500-80	SC3510-80	SC3500-120	SC3510-120
Measurement area length x width (at height) x * y (z)	Start expanded area	55 mm x 42 mm at 110 mm		87.5 mm x 62.5 mm at 171 mm	
	Start	67.5 mm x 46 mm at 120 mm		107.5 mm x 70 mm at 191 mm	
	Mid	80 mm x 50 mm at 130 mm		120 mm x 75 mm at 206 mm	
	End	77.5 mm x 52 mm at 140 mm		123.5 mm x 80 mm at 221 mm	
	End expanded area	75 mm x 54 mm at 150 mm		122 mm x 82.5 mm at 241 mm	
Working distance	z	130 ±10 mm		206 ±15 mm	
	expanded z	130 ±20 mm		206 ±35 mm	
Resolution	x, y	40 μm		60 μm	
	z ¹	1.0 μm		2.0 μm	
Repeatability	z(σ) ¹	< 0.4 μm		< 0.8 μm	
Acquisition time ^{2 3}		0.2 ... 0.4 s			
Light source		LED			
Power supply		18 ... 30 VDC			
Max current consumption		0.5 ... 2.5 A			
Digital interface		Gigabit Ethernet (GigE Vision / GenICam) / PROFINET ⁴ / EtherCAT ⁴ / EtherNet/IP ⁴			
Digital in-/outputs		4 digital I/Os for which parameters can be set (for external trigger, sensor control, output of sensor states)			
Connection		8-pin M12 socket for Gigabit Ethernet, 12-pin M12 socket for digital I/Os, 4-pin M12 plug for power supply			
Mounting		3 mounting holes (installation can be reproduced with centering sleeves)			
Temperature range	Storage	-20 ... 70 °C (-4 ... +158 °F)			
	Operation ⁵	0 ... 45 °C (+32 ... +113 °F)			
Shock (DIN-EN 60068-2-27)		15 g / 6 ms in XY-Achse, 1000 shocks each			
Vibration (DIN-EN 60068-2-6)		2 g / 20 ... 500 Hz in XY axis, 10 cycles each			
Protection class (DIN-EN60529)		IP67			
Material		Aluminum housing, passive cooling; external cooling optionally available (see accessories)			
Weight		1.9 kg			
Control and Display Elements		3 LEDs (for sensor state, power, data transmission)			
Sensor-SDK		Micro-Epsilon 3D Sensor-SDK			
3D evaluation software		Micro-Epsilon 3DInspect			
Functional extension		-	3DInspect Automation	-	3DInspect Automation

1) Measured on measuring object with cooperative surface in the mid of the measuring range while the “EnhancedSNR” parameter is enabled and a 3x3 mean value filter is used once at a consistent room temperature of 20 ± 1 °C.

2) Duration that the sensor requires for the image acquisition of the pattern projections (without processing and evaluation time).

3) Applies for exposure times < 6,800 μs

4) Connection via 2D/3D gateway interface module

5) Max. permissible operating temperature depends on installation scenario, thermal connection and operating mode.

If necessary, external heat dissipation must be used to ensure that the sensor’s internal temperature of 60 °C is not exceeded.

3.3 LED Displays

LED LED	Meaning
Off	LED not active
Constant green	LED active

LED State	Meaning
Flashing orange	Initialization of sensor hardware
Flashing green	Initialization of communications interface
Constant green	Sensor is ready for operation
Flashing orange-green	Error during initialization of sensor hardware Communication with sensor possible
Constant red	Error during initialization No communication with sensor possible

LED Power	Meaning
Off	No operating voltage or operating voltage too low
Constant green	Operating voltage applied
Constant red	Error, operating voltage too high

LED Data (Link/Act)	Meaning
Link LED (left):	
Constant orange	Gigabit Ethernet connection established
Constant green	100 Mbit Ethernet connection established
Off	10 Mbit Ethernet connection established
Act LED (right):	
Green	Active data transmission
Off	No data transmission

LED I/O	Meaning
	Reserved



Fig. 3 LED Displays

4. Delivery

4.1 Unpacking, Included in Delivery

- 1 Sensor surfaceCONTROL 3D 35xx
- 1 Assembly instructions
- 1 Calibration final inspection
- 3 Protective caps
- 1 ECR3000-5 supply cable 5 m
- 1 SCR3000X-5 Ethernet interface cable 5 m

▶ Carefully remove the components of the measuring system from the packaging and ensure that the goods are forwarded in such a way that no damage can occur.

▶ Check the delivery for completeness and shipping damage immediately after unpacking.

▶ If there is damage or parts are missing, immediately contact the manufacturer or supplier.

4.2 Storage

Humidity: 20 ... 80 % (non-condensing)

Storage temperature -20 ... +70 °C (-4 ... +158 °F)

5. Installation and Mounting

5.1 Attachment and Mounting

- using 2 or 3 screws M5, screwed directly
- using 2 or 3 screws M4, screwed pushed through

Depending on the installation position, it is recommended to define the sensor position using centering elements and fitting bores.

The cylindrical counterbore $\varnothing 8H7$ is intended for the position-defining centering elements. This allows for the sensor to be mounted in a reproducible and exchangeable way.

➡ The mounting dimensions refer to the dimensional drawings.

NOTICE

Pay attention to careful handling during mounting and operation.
Damage to or destruction of the sensor.

➡ Mount the sensor by means of screws type M5 or by means of through bores for M4.

Bolt connection			
Through length	Screw	Washer	Torque
50 mm	M4 x ISO 4762-A2	A 4,3 ISO 7089-A2	1.9 Nm

Direct fastening		
Screw depth	Screw	Torque
min 14 mm	M5 x ISO 4762-A2	2.5 Nm

Fig. 4 Mounting conditions

NOTICE

The bearing surfaces surrounding the fastening holes (through-holes) are slightly raised. Mount the sensor only to the existing holes on a flat surface. Clamps of any kind are not permitted. Do not exceed torques.
Damage to or destruction of the sensor; inaccurate, erroneous measuring values.

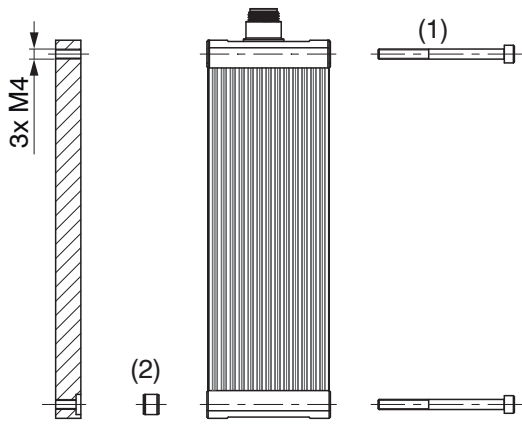

Fig. 5 Mounting example with bolt connection

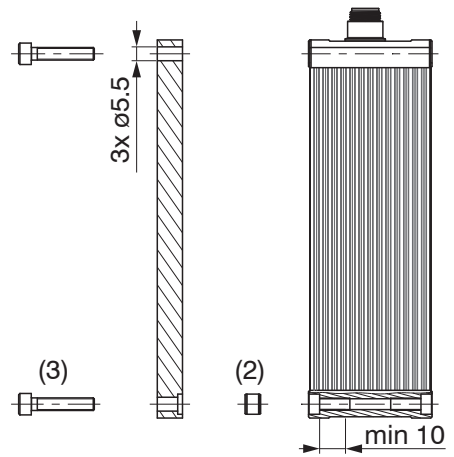

Fig. 6 Mounting example with direct fastening

Bolt connection:

- 3 threaded holes (M4)
- with centering element:
- additionally 2 cylindrical counterbores 8H7 depth 1.9 - 2 mm

- 1) Screw M4
- 2) Centering element

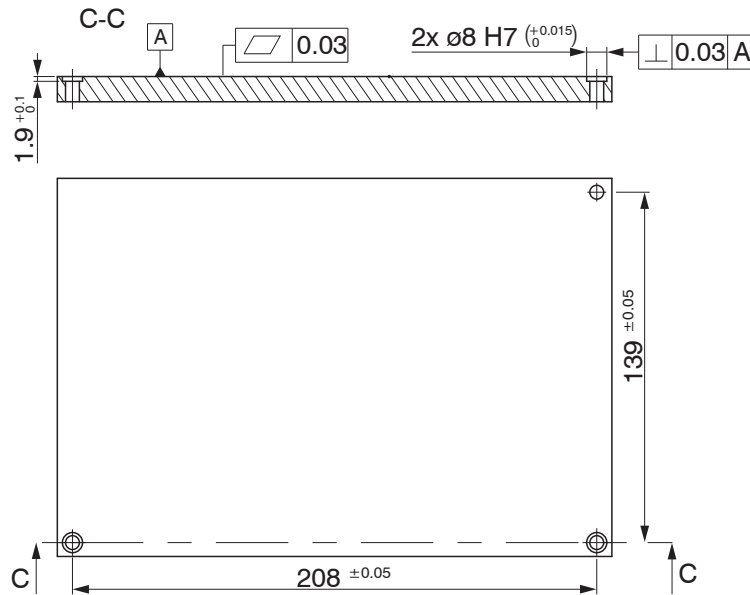

Fig. 7 Dimensional drawing mounting bores, dimensions in mm, not to scale

Direct fastening:

- 3 bores Ø 5.5
- with centering element:
- additionally 2 cylindrical counterbores 8H7 depth 1.9 - 2 mm

- 3) Screw M5

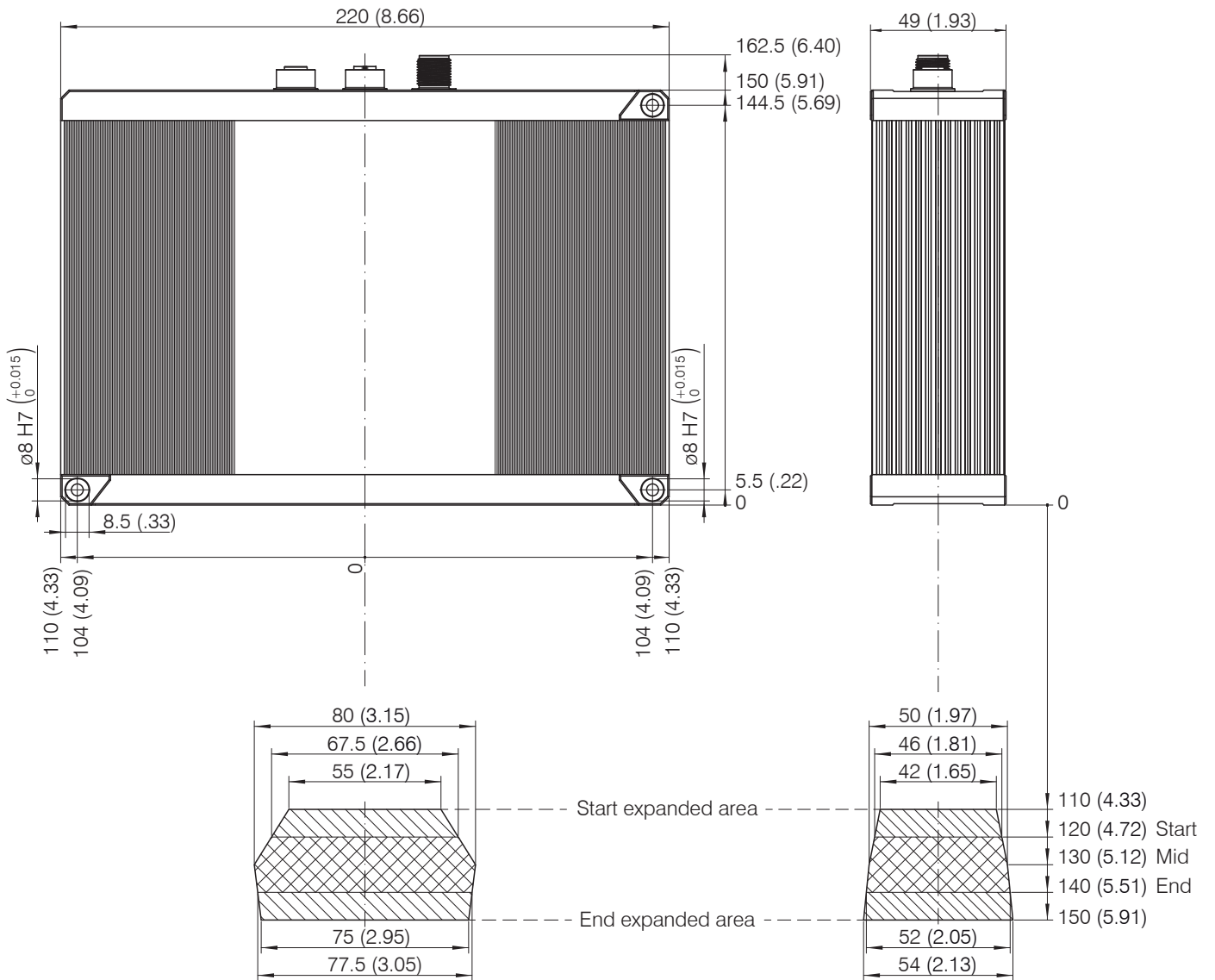

Fig. 8 Dimensional drawing sensor surfaceCONTROL 3D 35xx-80, dimensions in mm (inches)

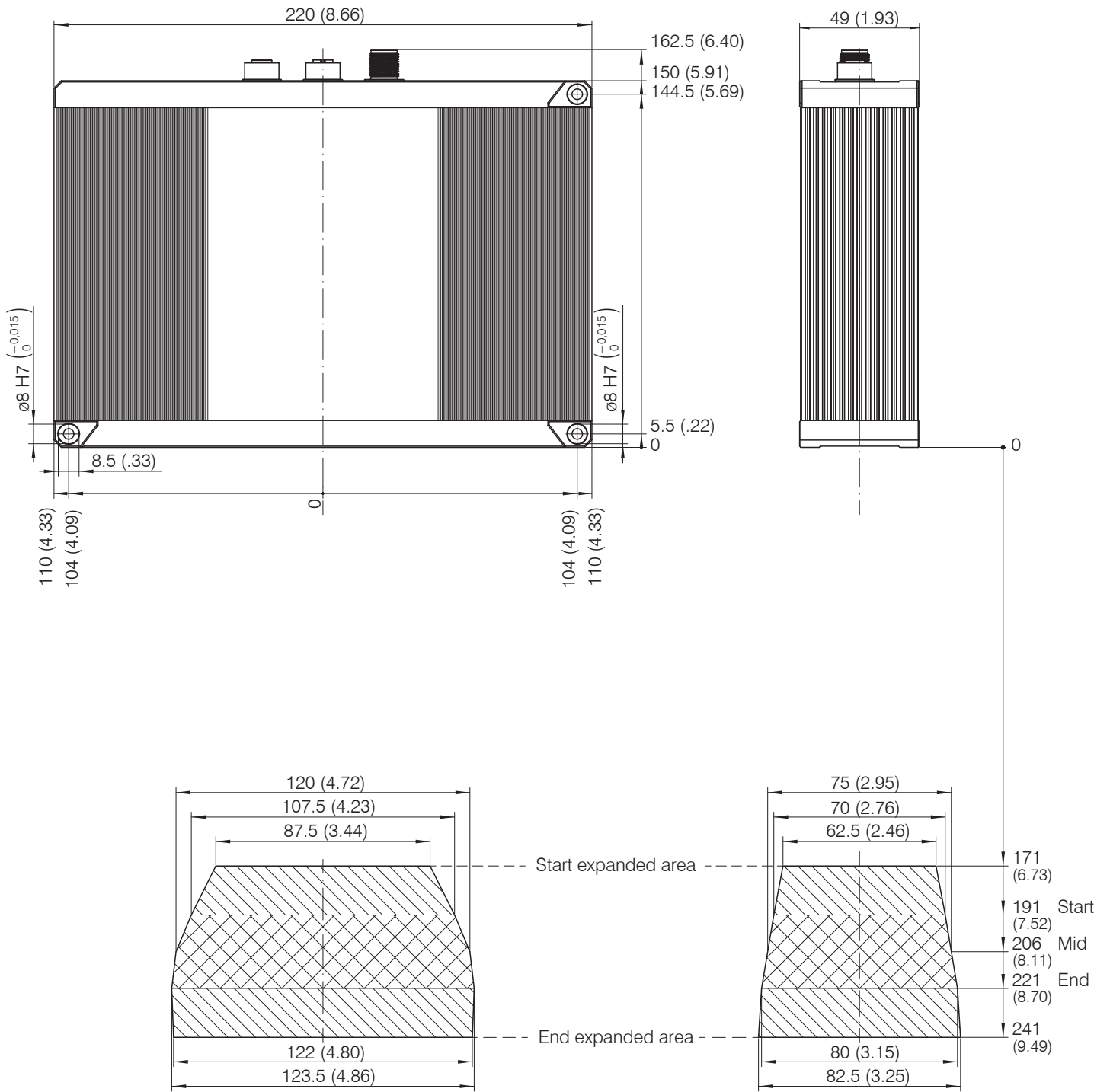

Fig. 9 Dimensional drawing sensor surfaceCONTROL 3D 35xx-120, dimensions in mm (inches), true to scale

5.2 Electrical Connections

5.2.1 General



Fig. 10 Arrangement of connections

Power	Power supply connection
Data	Gigabit Ethernet connection
I/O	Multi-function connection

5.2.2 Supply Voltage (Power)

The power supply connection in the form of a 4-pin M12 round connector has a current carrying capacity of up to 2 A per pin.

Designation	Pin no.	Cable color ECR3000-x	Notes	Connection view
$+U_B$	1	Brown	18 V ... 30 V DC (rated value 24 V)	<p>The diagram shows a circular 4-pin connector with four pins arranged in a square. The pins are numbered 1 (bottom-left), 2 (bottom-right), 3 (top-right), and 4 (top-left).</p>
$+U_B$	2	White		
GND	3	Blue	0 V	
GND	4	Black		
Screen	Housing			View: Plug on housing side

Fig. 11 Pin assignment of the power supply connection

The operating voltage is protected against polarity reversal. Use only shielded lines or original cables from the accessories program for the power supply connection or the outputs.

Micro-Epsilon recommends the ECR3000-x shielded supply cable.

5.2.3 Gigabit Ethernet Connection

The Ethernet connection is the standard connection to the PC. The sensor supports transmission at 1 Gbit/s. An 8-pin X-coded M12 socket is installed in the housing.

RJ-45 connector		8-pin X-coded socket (housing side)		
Pin no.	Color of stranded hook-up wire	Pin no.	100BaseTX	1000BaseTX
1	White (orange)	1	Tx+	D1+
2	Orange	2	Tx-	D1-
3	White (green)	3	Rx+	D2+
4	Blue	8		D3+
5	White (blue)	7		D3-
6	Green	4	Rx-	D2-
7	White (brown)	5		D4+
8	Brown	6		D4-

 <p>View on pin side of male cable connector</p>	 <p>View: Socket on housing side</p>
--	---

Fig. 12 Pin assignment of Gigabit Ethernet connection according to IEC 61076-2-109

For use with an Ethernet connection, we recommend the SCR3000X-x Gigabit Ethernet connection cable; cable length x in meters. Characteristics: 4 x 2 x 0.14 mm²; shielded.

Due to the high data rate, we recommend a high-quality Ethernet PC plug-in card, for example, Intel-Pro/1000 PT. Preferably the sensors should be connected directly to the network connection or using a high-quality switch. A hub would cause massive data collisions and may not be used. On the PC, one or more network cards should always be intended solely for the sensors.

Operating the sensors via Ethernet requires no additional driver installation. However, the network settings must be specified correctly:

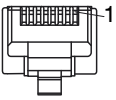
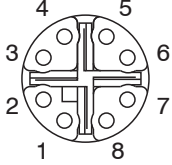
- The sensor supports DHCP. This setting is enabled by default and has priority over searching in the link local network.
- A fixed IP address can be assigned.
- Various network settings (e.g. firewall or packet filters) can interfere with communications with the sensor.
- The sensor supports jumbo frames up to 9014 bytes/packet; however, in that case all network components must also support jumbo frames up to that size.

5.2.4 Multi-Function Connection I/O

Interfaces and signals for external control of the sensor or for outputting sensor states and data are provided via the multi-function connection. The four connections operate either as inputs or outputs.

Designation	Pin no.	Cable color PCR3000-x	Notes	Connection view
reserved	9	Red		 <p>View: Socket, housing side</p>
reserved	2	Blue		
reserved	3	White		
reserved	1	Brown		
reserved	12	Red-blue		
reserved	11	Gray-pink		
reserved	10	Purple		
GPIO1	4	Green	General purpose IO 1 hardware trigger	
GPIO2	6	Yellow	General purpose IO 2	
GPIO3	8	Gray	General purpose IO 3	
GPIO4	5	Pink	General purpose IO 4	
GND GPIO	7	Black	Ground connection GPIO	
Screen	Housing		Not electrically connected to GND GPIO	

Fig. 13 Pin assignment of the multi-function connection

The multi-function connection is a 12-pin M12 round connector. The connecting line is intended to be up to 35 m long; however, the cable must be shielded at any length. Micro-Epsilon recommends using the PCR3000-x multi-function cable.

5.2.4.1 Digital Signals

The four digital connections of the multi-function interface provided can operate optionally as inputs or outputs. They are configured using the software. All digital ports share a joint ground GND GPIO.

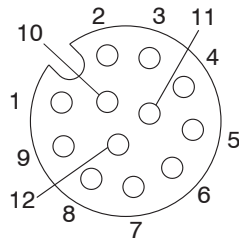
External auxiliary power (max. 30 V) is required to use the outputs.

The digital signals are not suitable for brief signal pulses or time-critical signals. The exception is port 1, which, when configured correctly, can be used as a hardware trigger to start a measurement and is directly connected to the sequence control in the sensor.

The functionality of the digital signals can be programmed, see Fig. 14. In addition to direction, polarity can also be switched for the inputs and outputs. Internal sensor signals can be assigned to the digital outputs, for example, to control additional connected devices.

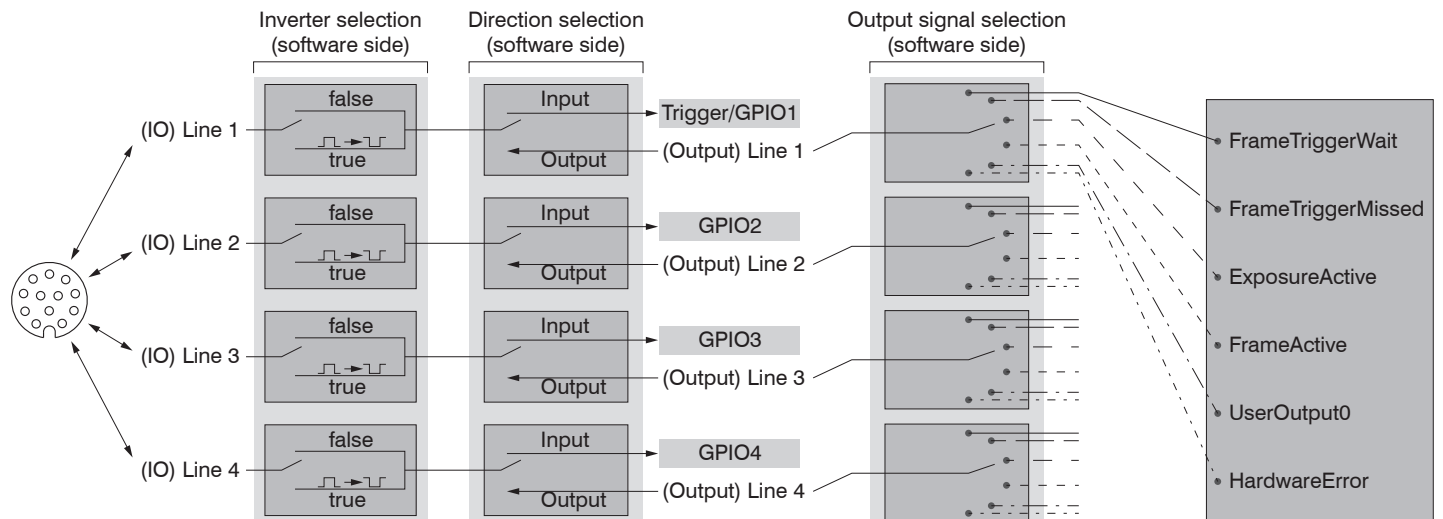

Fig. 14 Programmable inputs and outputs

The outputs can optionally be assigned the internal signals below:

Internal signal	Description
UserOutput0	Digital output signal that can be set via Genicam
FrameTriggerWait	Sensor is ready for next measurement
FrameTriggerMissed	(External) trigger was missed (sensor was not yet ready for measurement)
FrameActive	3D measurement in sensor is active (start at exposure of first image, end at completion of data transmission via GigE)
ExposureActive	Image sequence recording is enabled for current frame (start at first image, end at last image transmission)
HardwareError	Critical error in sensor: Hardware error or sensor has become too hot.

Fig. 15 Internal signal for digital outputs

5.2.4.2 Electrical Parameters of Digital Inputs, Multi-Function Connection

The switching levels of the digital inputs are defined based on HTL logic:

Low 0 ... 3 V, High 11 ... 24 V (up to 30 V permitted). Maximum input current is internally limited to 5 mA.

The GPIO_1 input can also be used as a trigger signal. The minimum pulse duration when used as a trigger signal is 50 μ s. Switching delay until a measurement is triggered is at most 10 μ s.

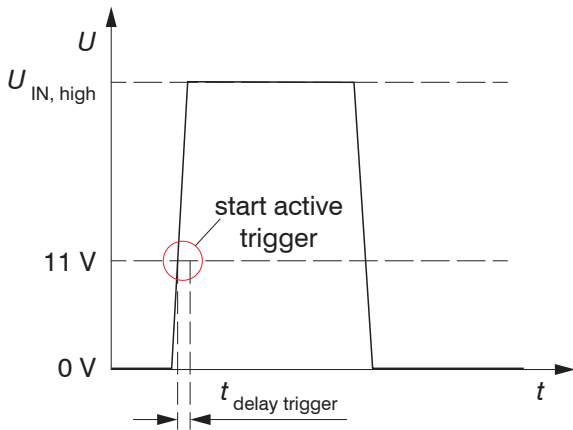

All inputs can be used as logical inputs, but not for time-critical tasks.

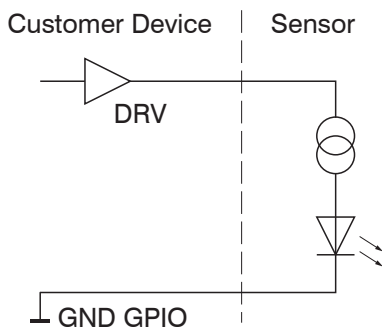

5.2.4.3 Electrical Parameters of Digital Outputs, Multi-Function Connection

The digital outputs require an external auxiliary voltage between 5 V and 30 V as well as load resistance. They can be operated at a load current of at most 100 mA. This may occur, for example, by using an NPN-switching input module of a control.

The outputs are switched using a SolidState relay and are low active.

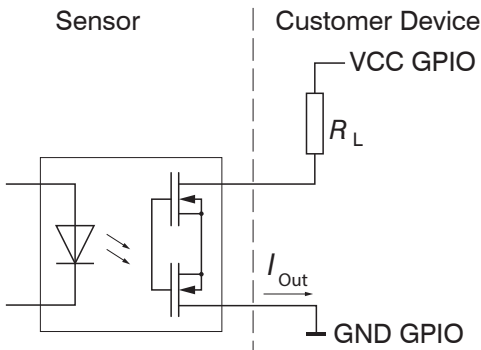

Fig. 16 Example for the timing behavior of an output at $VCC\ GPIO = 24\ V$, $I_{Out} = 10\ mA$, $R_L = 2.4\ k\Omega$

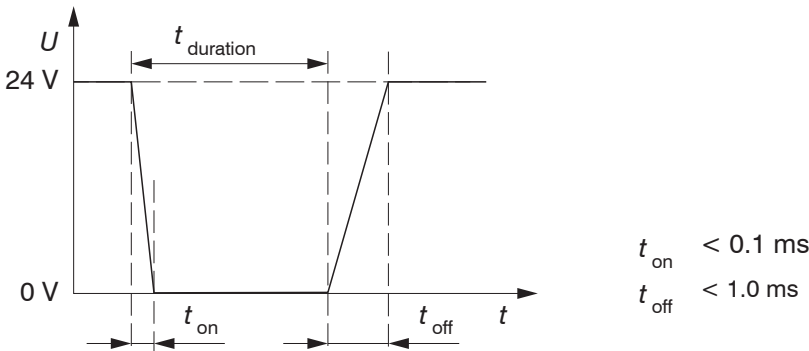

Fig. 17 Switching times of digital output

5.3 Installation Instructions

For all connection cables, use only the appropriate cables from the optional accessories.

NOTICE

Tighten the cable connectors. The recommended tightening/screwing torque is at most 1.0 Nm.

Do not apply force when tightening.

> Damage to or destruction of the sensor

Lay all connection cables in accordance with the generally applicable measuring technology regulations, i.e. for example not directly next to pulse-carrying lines, preferably in a separate cable duct.

Never bend the cables more tightly than the minimum bending radii.

MICRO-EPSILON recommends using the optionally available power supply PS2020, installation of top-hat rail, input 230 VAC, output 24 VDC/2.5 A, see Appendix.

5.4 Commissioning

NOTICE

The sensor may only be connected to peripherals when it does not carry power, that is, only when the operating voltage has been switched off.

- ▶ Mount the sensor according to the installation instructions, see Chap. 5.1.
- ▶ Connect the sensor to the Ethernet cable.
- ▶ Connect the Ethernet cable to the PC.
- ▶ Connect the sensor to the power supply.

6. Operation

6.1 Turning On

➤ Turn on the external DC voltage supply (24 VDC).

The `Power` LED is constantly illuminated green if sufficient operating voltage is applied.

The `State` LED flashes orange and green during hardware connection and initialization.

After completion, it is constantly illuminated green. For more information, see the “LED Displays” section, see Chap. 3.3.

• The surfaceCONTROL 3D 35xx sensor requires a warm-up time of typically 60 minutes for precise measurements.

6.2 Operating Programs

Various programs are provided for operation of the sensor.

- 3D View visualizes in space three-dimensional point data that have been detected with surfaceCONTROL 3D 35xx.
- 3DInspect solves industrial 3D measurement tasks.
- You can use surfaceCONTROL DefMap3D 7.0 for the individual analysis of surfaces with surfaceCONTROL 3D 35xx.

6.3 Installation

6.3.1 Requirements

The following minimum system requirements are necessary for the operation of the operating programs:

- Windows 8 or 8.1, Windows 10 (each 64 Bit)
 - 1-GHz or higher processor (64 Bit)
 - 4 GB RAM
 - Screen resolution: 1280 x 1024
 - Graphic card / GPU with OpenGL 3.1 or higher
- Connect the sensor directly to the PC. Do not use hubs.

To be able to use the software the following steps must be followed:

1. Install the Ethernet interface hardware, if not already installed.
2. Install the software.
3. With DefMap3D, connect and license the USB dongle required for this.
4. Connect the surfaceCONTROL 3D 35xx measuring system via Ethernet to the PC.

• If your network card supports the `VLAN` option, this option must be disabled.

6.3.2 Connecting surfaceCONTROL 3D 35xx to the PC

To connect surfaceCONTROL 3D 35xx via Ethernet to the PC, proceed as follows:

1. Complete the installation of the software.
2. Connect surfaceCONTROL 3D 35xx to the PC using the Ethernet interface.
3. Turn on the power supply.
4. Wait until the surfaceCONTROL 3D 35xx measuring system is recognized by the PC. This takes about 1 minute.

• To be able to operate the sensor, the PC and the sensor must be located in the same subnet.

You can now operate the surfaceCONTROL 3D 35xx measuring system using the operating programs listed above.

6.4 Notes for Operation

6.4.1 Measuring Range

The measuring range of the sensors is factory-set.

The area illuminated by the projector is relevant for the actual measuring range of the sensor. The cameras are arranged in such a way that both cameras capture the area illuminated by the projector within the complete measuring volume.

The measuring range in Z direction is trapezoidal due to the point-shaped light source of the projector and the fan-out over the lens.

6.4.2 Calibration

The calibration of the sensor serves to determine the orientation of the camera coordinates in the coordinate system of the inspection system and is carried out with the aid of a pre-calibrated calibration target.

The sensor is factory calibrated upon delivery. An acceptance report is included with each sensor.

6.4.3 Positioning of Sensor and Test Object

6.4.3.1 General

- Note the following instructions for optimum positioning of the sensor and test object.
- 1
- Observe an optimum distance between the sensor and the surface of the test object, see Chap. 3.2.
- Align the sensor with predominantly diffusely reflecting surfaces almost perpendicular to the surface. To avoid direct reflection, we recommend that you tilt the sensor by a few degrees.
- In the case of partially glossy surfaces, reflections from the test object can be reduced by inclining the sensor by up to 30° with respect to the surface of the test object.

6.4.3.2 Alignment with Crosshair

You will achieve the best results in the mid of the measuring range (focal range of cameras).

- ▶ Use the positioning pattern to easily and optimally align the sensor in the mid of the measuring range. Align the pattern of the projection with the superimposed pattern.

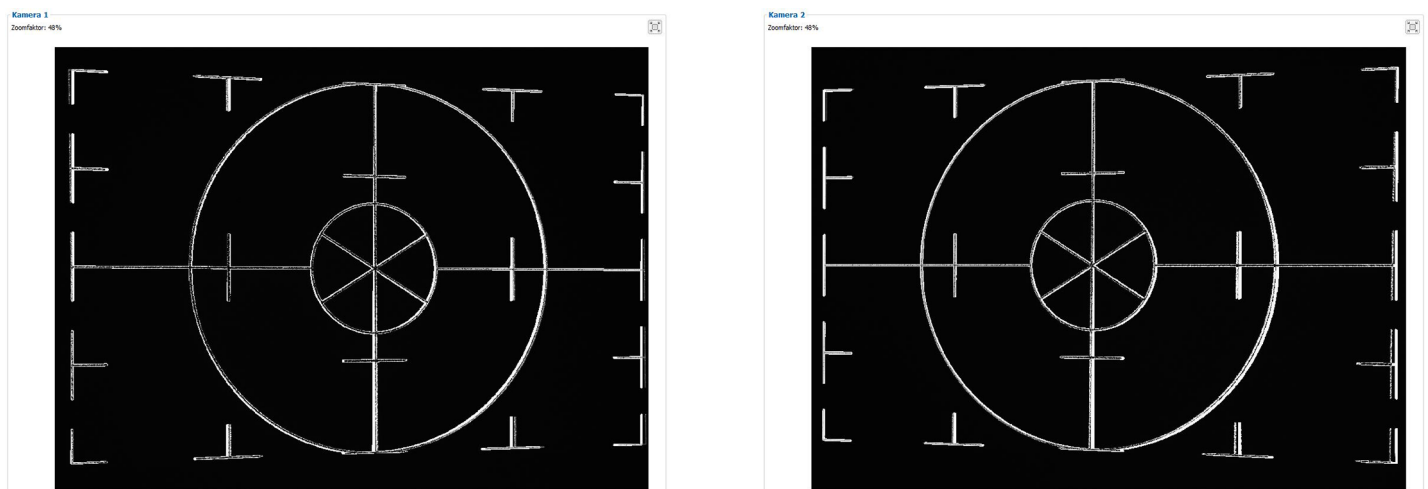

Fig. 19 Result of camera images when aligned with crosshair

Examples:

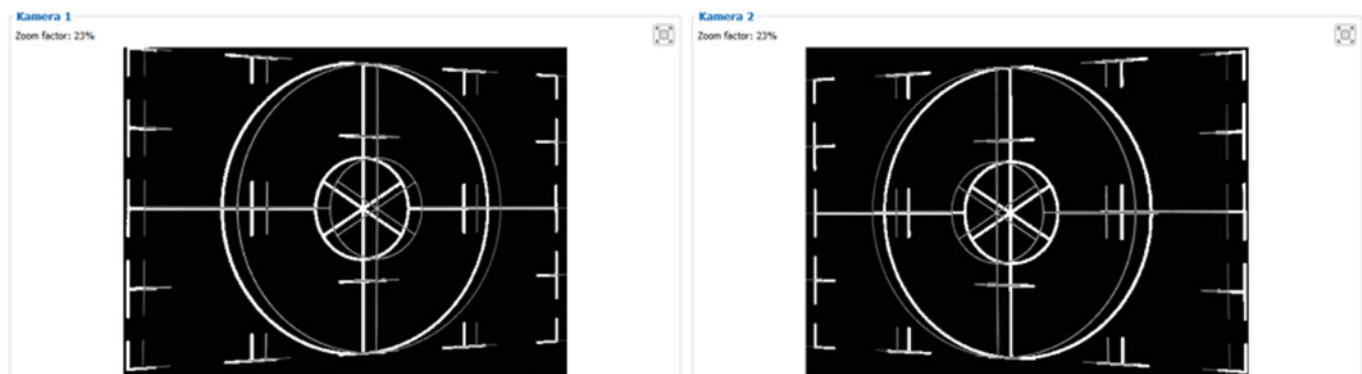

Fig. 20 Distance too short (6 mm above the zero plane)



Fig. 21 Distance too large (4 mm under the zero plane)

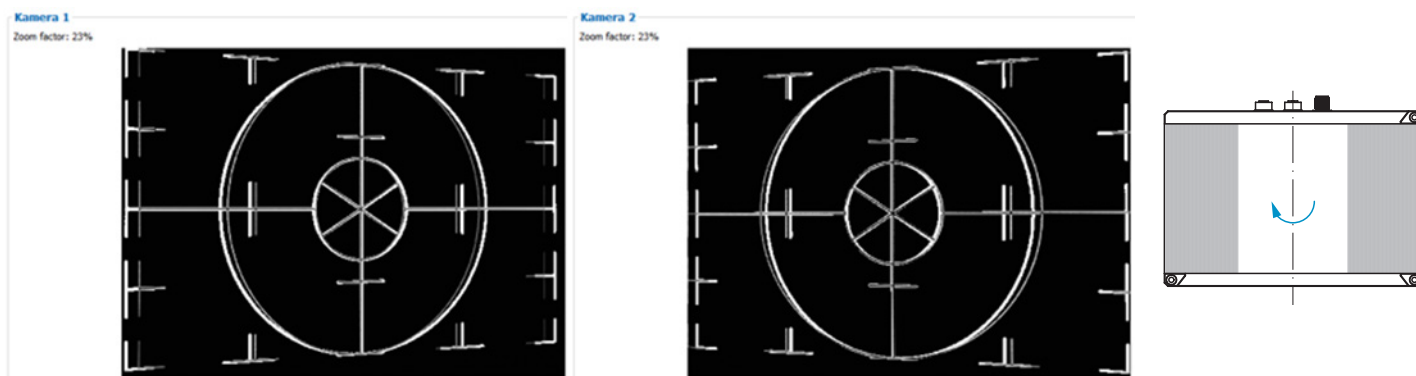

Fig. 22 Lateral tilt (plane angle x : 7° tilted around the y -axis), distance correct

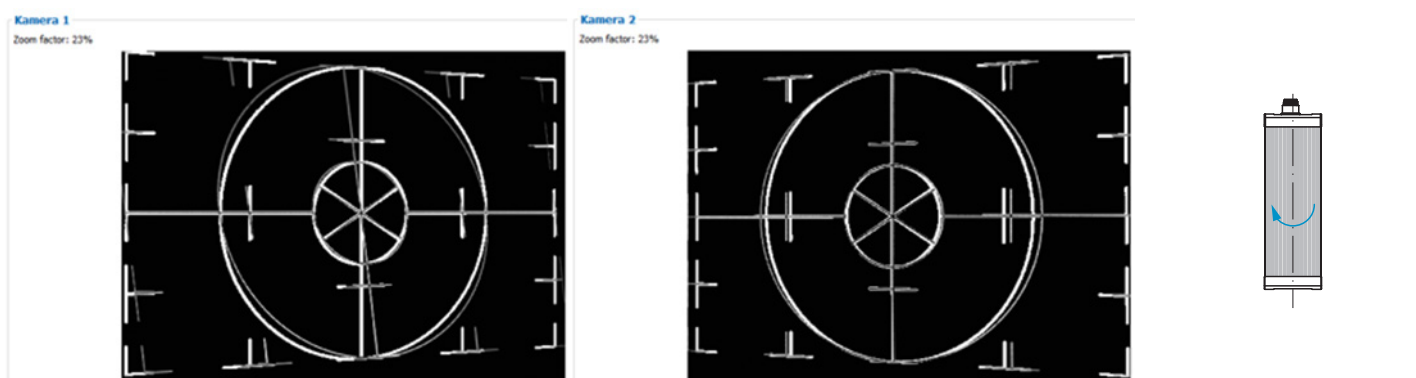

Fig. 23 Lateral tilt (plane angle y : 16° tilted around the x -axis), distance correct

Further details can be found in the respective operating instructions of the software provided by Micro-Epsilon or in the GenICam parameter description, see Chap. A 3.

6.4.4 Exposure

The projected fringe pattern should be well recognizable over the entire measurement plane (not too light/dark) in order to avoid overdriven and underdriven pixels.

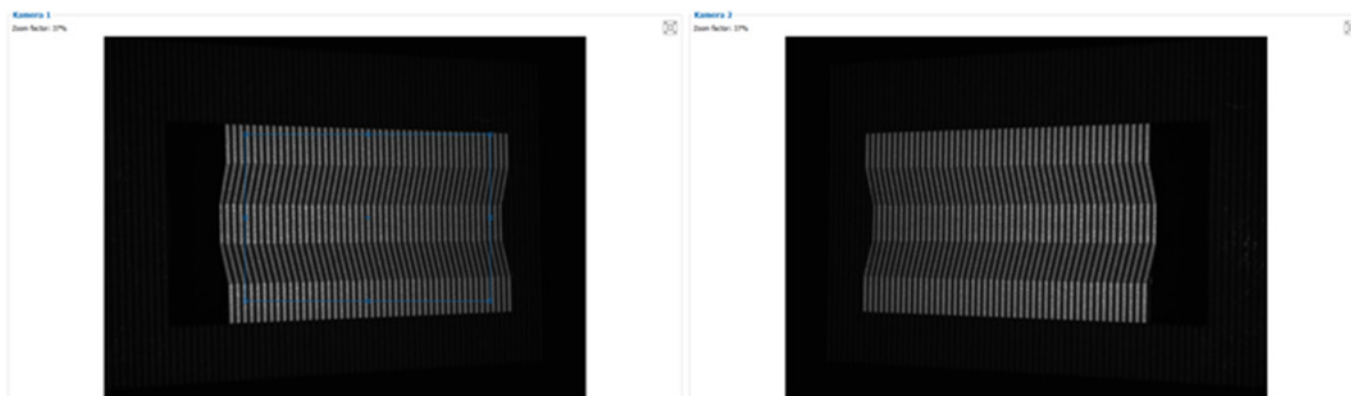

Fig. 24 Result of camera images with good exposure

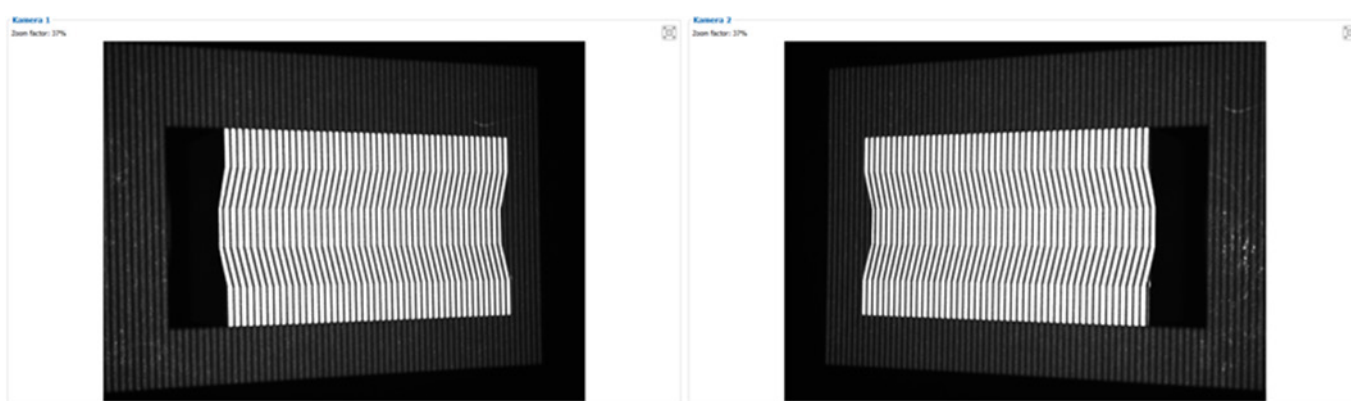

Fig. 25 Camera image, measuring object overexposed

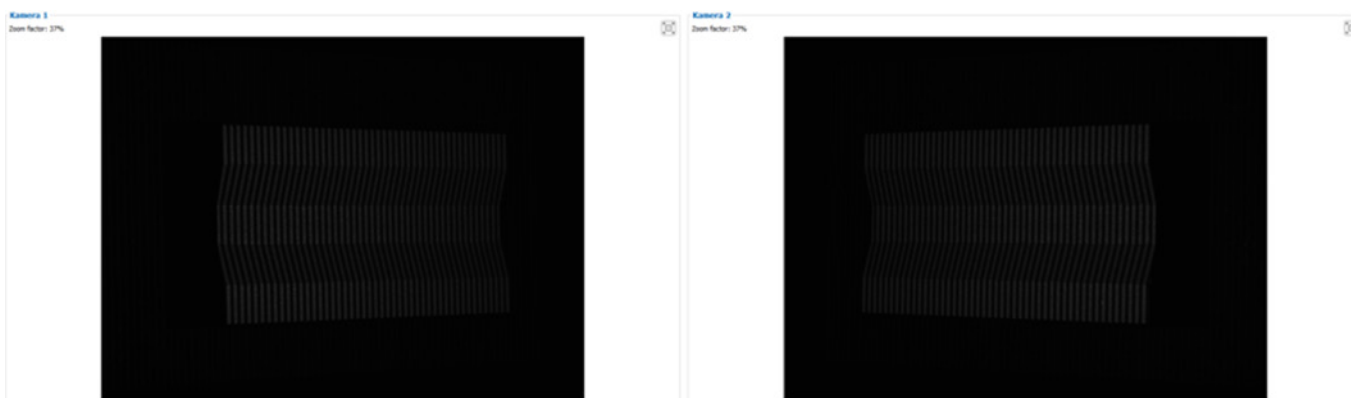

Fig. 26 Camera image, measuring object underexposed

6.5 Temperature

The sensor issues a warning when the internal temperature exceeds 60 °C.

The sensor refuses measurements when the internal temperature exceeds 63 °C.

The sensors turns off when the internal temperature exceeds 65 °C.

6.6 Error Influences

6.6.1 Reflection Factor of the Surface of the Target

The sensor evaluates the diffuse portion of the reflected light. Any statement about a minimum reflection factor is only possible with reservations. A preliminary examination is necessary to use the sensor on reflective, highly reflective or transparent objects.

6.6.2 Color Differences

Color differences between test objects result in apparent changes of the surface texture of the test object and thus also influence the calculation of the 3D data from the acquired images. Therefore color differences can result in increased measurement inaccuracies and reduced detection performance.

As the exposure parameters can only be changed as a whole, careful matching of the exposure to the target surface is recommended.

6.6.3 Temperature Influences

When the sensor is commissioned, a warm-up time of at least 60 minutes is required to achieve uniform temperature distribution in the sensor. Large temperature fluctuations and changes of the ambient climate act directly on the sensor and its fixing elements and can thus change the detection performance.

6.6.4 External Light

For external light suppression, the sensor is equipped with corresponding filters in front of the camera lenses. They allow only a narrow (band-limited) wavelength range around the wavelength of the light projected onto the test object. In general, additional shielding of external light directly emitted on the target or reflected in the sensor is recommended for highly accurate measurements.

- Pay particular attention to unwanted reflections of the projected structured light outside the target area (background, object holder or similar) which can be reflected back again into the view area of the sensor.
- Matt black surface coatings are recommended for all objects outside the measuring range (object holders, transport equipment, grippers or similar).

6.6.5 Mechanical Vibrations

As high resolutions in the μm range will be achieved with the inspection system, particular attention must be paid to as vibration-free a set-up of sensor and test object as possible.

6.6.6 Surface Roughness and Texture

Surface roughnesses of the order of $5\ \mu\text{m}$ and more, as well as textures on the surface, result in increased "surface noise". In addition, direct reflections of the projected light can also occur on grinding marks or small scratches on the surface. This can result in inaccurate measured values. Remedy can possibly be provided by adjusting the exposure or by changing other sensor settings.

6.6.7 Shadowing Effects and Multiple Reflections

Shadowing effects and multiple reflections occur particularly frequently on strongly curved surfaces. Steep edges and large differences in height lead to certain areas on the test object being underprojected. Furthermore, parts of the test object cannot be detected completely by the cameras, which leads to a loss of measuring points on the surface. This effect can be diminished by a change in orientation of the sensor to the surface.

Multiple reflections of the projected pattern from certain areas of the surface to other areas of the surface lead to overlaps of the original pattern. This can result in inaccurate measured values.

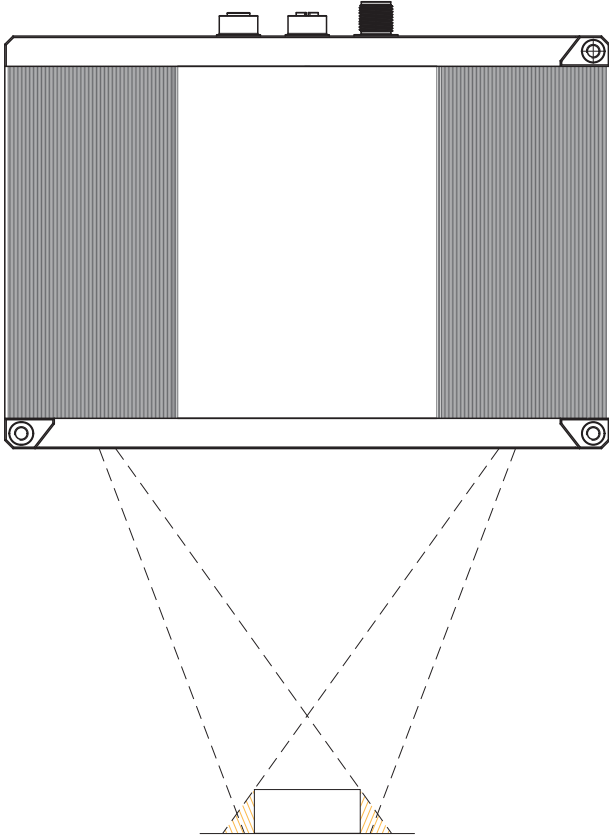

Fig. 27 Shadowing of the receiver

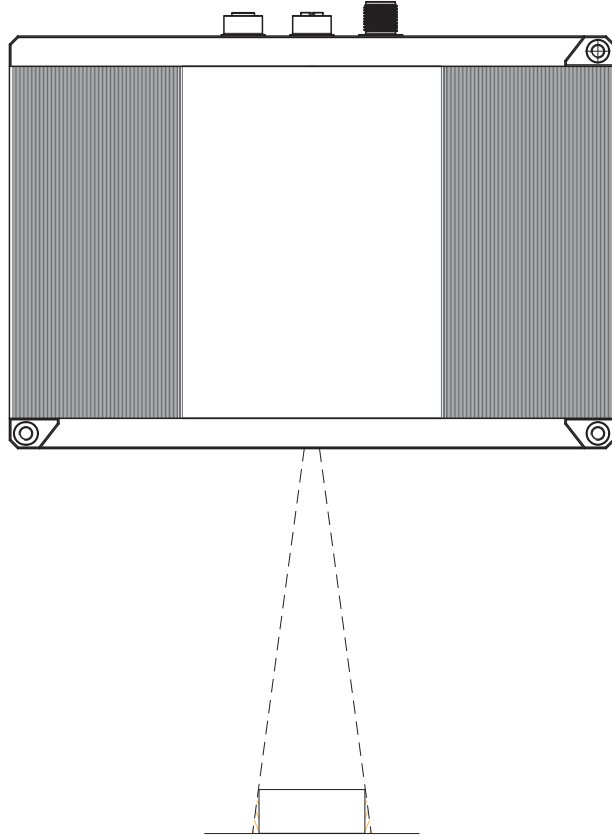

Fig. 28 Shadowing of projection

6.7 Cleaning

A periodically cleaning of the protective housings is recommended.

Dry cleaning

This requires a suitable optical antistatic brush or blow off the panels with dehumidified, clean and oil free compressed air. Use a dry, clean, soft, lint-free, antistatic lens cloth to clean the protective glass.

Wet cleaning

Use a clean, soft, lint-free cloth or lens cleaning paper and pure alcohol (isopropanol) for cleaning the protective housing. Do not use commercial glass cleaner or other cleaning agents.

7. Liability for Material Defects

All components of the device have been checked and tested for functionality at the factory. However, if defects occur despite our careful quality control, MICRO-EPSILON or your dealer must be notified immediately.

The liability for material defects is 12 months from delivery. Within this period, defective parts, except for wearing parts, will be repaired or replaced free of charge, if the device is returned to MICRO-EPSILON with shipping costs prepaid. Any damage that is caused by improper handling, the use of force or by repairs or modifications by third parties is not covered by the liability for material defects. Repairs are carried out exclusively by MICRO-EPSILON.

Further claims can not be made. Claims arising from the purchase contract remain unaffected.

In particular, MICRO-EPSILON shall not be liable for any consequential, special, indirect or incidental damage. In the interest of further development, MICRO-EPSILON reserves the right to make design changes without notification.

For translations into other languages, the German version shall prevail.

8. Service, Repair

If the sensor or sensor cable is defective:

- If possible, save the current sensor settings in a parameter set, see 3D-View, menu `Parameters > Save parameters to file`, in order to load the settings back again into the sensor after the repair.
- Please send us the affected parts for repair or exchange.

If the cause of a fault cannot be clearly identified, please send the entire measuring system to:

MICRO-EPSILON Optronik GmbH
Lessingstraße 14
01465 Langebrück / Germany

Tel. +49 (0) 35201 / 729-0
Fax +49 (0) 35201 / 729-90
optronic@micro-epsilon.de
www.micro-epsilon.com

9. Decommissioning, Disposal

➡ Remove all cables from the sensor.

Incorrect disposal may cause harm to the environment.



➡ Dispose of the device, its components and accessories, as well as the packaging materials in compliance with the applicable country-specific waste treatment and disposal regulations of the region of use.



Appendix

A 1 Accessories

ECR3000-xx		<p>Power supply cable; length $x = 2$ to 35 m, 4-pin M12 socket to open ends, Cable diameter: approx. 6.8 mm, Minimum bending radius at continuous movement: 10x cable diameter</p> <p>Number of bending cycles to be expected: With a torsion of $\pm 360^\circ/\text{m}$: 2 million cycles</p> <p>Suitable for use with drag chains and robots</p>
SCR3000X-xx		<p>Gigabit-Ethernet interface cable, length $x = 2$ to 35 m, 8-pin M12 connector to 8-pin RJ45 connector, Cable diameter: approx. 7 mm, Single bending during installation: 5x cable diameter, Minimum bending radius at continuous movement: 10x cable diameter.</p> <p>Number of bending cycles to be expected: With a torsion of $\pm 180^\circ/\text{m}$: 2.2 million cycles.</p> <p>Suitable for use with drag chains and robots</p>
PCR3000-xx		<p>Multi-function cable, length $x = 2$ to 35m, for power supply, digital inputs (TTL or HTL), RS422 (half-duplex).</p> <p>12-pin M12 plug to open ends, Cable diameter: approx. 7 mm, Single bending during installation: 5x cable diameter, Minimum bending radius at continuous movement: 7.5x cable diameter</p> <p>Number of bending cycles to be expected: With a torsion of max. $\pm 180^\circ/\text{m}$ and a bending radius of 12x cable diameter: 1 million cycles.</p> <p>Suitable for use with drag chains and robots</p>

A 2 Optional Accessories

Tripod		<p>Mounting and alignment, compact tripod incl. adapter and quick release plate with suitable bore holes and dovetail connection</p>
PS3000		<p>Table power pack to supply one sensor, Input 80-264 VAC 47-63 Hz ~ 0.4 to 0.8 A, Output 24 VDC/3.54 A</p>
PS2020		<p>Power supply for mounting on DIN rail, Input 230 VAC, Output 24 VDC/2.5 A to supply one sensor surfaceCONTROL 3D 35xx</p>

Jointed arm		Holder with jointed arm for mounting and alignment of surfaceCONTROL 3D sensors, including clamping base, flexible holder rod made of aluminum with mechanical central clamping and sensor adapter plate with bore holes
2D/3D Gateway		Fieldbus coupler for 2D/3D sensors combined with 3DInspect, configurable for PROFINET, EtherNet/IP and EtherCAT, Evaluations from 3DInspect can be transmitted to a PLC via one of these fieldbus systems, Sensor settings can be loaded by a controller via 3DInspect using parameter set mapping,
Demo case		Complete equipment with tripod and power supply unit incl. case

A 3 Genicam surfaceCONTROL Parameters

Details about setting the parameters are available in the software description, see 3D View operating instructions.

Parameter Description

Observe the notes below if you operate the sensor with a third party library for Genicam/GigE Vision:

- The library must support GigE Vision 2.1. In particular, `MultiPart` mode must be supported.
- Three sources are available to set the parameters of the sensor, see the `SourceSelector` description below. However, data are always transmitted using `StreamChannel 0`. Before starting data transmission with the `AcquisitionStart` command, the entry `Source0` must be selected as `SourceSelector`.
- The network card used should be configured as follows:
 - Jumbo frames: enable/use largest possible value
 - Interrupt throttling: enable
 - Interrupt throttling rate: adaptive
 - Receive buffer: use largest possible value
- The `Coord3D_C32f` pixel format is used for 3D measurements. If this pixel format is not supported by the library used, the `Mono16` pixel format can be used as an alternative. In that case, however, the resolution or measuring range is limited.
- The operating mode and sensor data transmitted are controlled using the parameter `ComponentEnable` and the associated selectors `SourceSelector`, `RegionSelector` and `ComponentSelector`, as well as via `TriggerMode` and `TriggerSoftware`. The following modes are possible, among others:
 - Setup operation (continuous transmission of raw images):
 - `TriggerMode = Off`
 - `ComponentEnable [Source1][Region0][Intensity] = 1`
 - `ComponentEnable [Source2][Region0][Intensity] = 1`
 - Set all other selector combinations for `ComponentEnable` to 0
 - `SourceSelector = Source0`
 - Command `AcquisitionStart`
 - Measuring operation 3D (triggered continuous 3D measurement):
 - `TriggerMode = On`
 - `TriggerSource = Software`
 - `ComponentEnable [Source0][Scan3dExtraction0][Range] = 1`
 - If you want a mask image for invalid points:
`ComponentEnable [Source0][Scan3dExtraction0] [Confidence] = 1`
 - Set all other selector combinations for `ComponentEnable` to 0
 - `SourceSelector = Source0`
 - Command `AcquisitionStart`
 - Trigger any number of measurements by using command `TriggerSoftware`

Name	Description	Documentation Text
Device Control		
DeviceTemperatureSelector	Selects the location within the device, where the temperature will be measured.	Serves as a switch for the temperature sensor to be read: Internal - internal sensor temperature Cpu - processor temperature CpuBoard - temperature of processor's circuit board LED - LED temperature CameraSensorBoard1 - internal temperature of camera #1 CameraSensorBoard2 - internal temperature of camera #2
DeviceTemperature [DeviceTemperatureSelector]	Device temperature in degrees Celsius (C).	Temperature of the component selected in DeviceTemperatureSelector.
Source Control		
SourceSelector	Selects the source to control.	Serves as a switch for the data source to be configured: - Source0: Virtual source for 3D measured data - Source1: Camera 1 - Source2: Camera 2

Image Format Control		
RegionSelector	Selects the Region of interest to control.	Serves as a switch for the parameters to describe the measuring field. Note that this switch also depends on the SourceSelector. The following settings are possible: - Region0: Describes the measuring field of the cameras [Source1] or [Source2] - Scan3dExtraction0: Describes the 3D measuring field [Source0]
Width[SourceSelector][RegionSelector]	Width of the image provided by the device (in pixels).	The number of pixels in u-direction in the camera image [Region0]. For [Scan3dExtraction0] the parameter specifies the number of 3D points in x-direction. The following combinations of SourceSelector and RegionSelector are permissible: - [Source0][Scan3dExtraction0] - [Source1/Source2][Region0]
Height[SourceSelector][RegionSelector]	Height of the image provided by the device (in pixels).	The number of pixels in v-direction in the camera image [Region0]. For [Scan3dExtraction0] the parameter specifies the number of 3D points in x-direction. The following combinations of SourceSelector and RegionSelector are permissible: - [Source0][Scan3dExtraction0] - [Source1/Source2][Region0]
PixelFormat[SourceSelector][RegionSelector][ComponentSelector]	Format of the pixels provided by the device.	Indicates the pixel format used for the selected component. Pixel formats Mono8 and Mono16 are available for the [Intensity] components. You can select Mono16 or Coord3D_C32f for the 3D data [Range].
ComponentSelector[SourceSelector][RegionSelector]	Selects a component to activate/deactivate its data streaming.	The following entries are available: - Intensity: Live camera image - Range: 3D data - Confidence: Mask for invalid points in 3D data The following combinations of SourceSelector, RegionSelector and ComponentSelector are permitted: - [Source0][Scan3dExtraction0][Range] - [Source0][Scan3dExtraction0][Confidence] - [Source1/Source2][Region0][Intensity]
ComponentEnable[SourceSelector][RegionSelector][ComponentSelector]	Controls if the selected component streaming is active.	Describes the components to be transmitted. It is used in particular to distinguish between setup operation (live mode) and measurement mode. Setup operation is enabled, if only the [Intensity] component is enabled.

Acquisition Control		
TriggerMode[TriggerSelector]	Controls if the selected trigger is active.	Enables trigger mode.
TriggerSoftware[TriggerSelector]	Generates an internal trigger. TriggerSource must be set to Software.	Command to trigger a measurement.
TriggerSource[TriggerSelector]	Specifies the internal signal or physical input Line to use as the trigger source.	Source of trigger signal. Available are Software (software trigger using Genicam command) and Line1 (hardware trigger from Input Line1).
TriggerActivation[TriggerSelector]	Specifies the activation mode of the trigger.	Sets whether the rising or falling slope of the trigger signal (only hardware trigger) is used to trigger a measurement.
ExposureTime	Sets the Exposure time in Microseconds.	The exposure time of the cameras in [μ s]
PatternDisplay	Defines the pattern that is shown during live stream.	Selects the image to be projected by the projector for live image operation. The following entries are available: - Bright image - Off - Fringe pattern - Positioning aid

Measurement Control		
GraycodeThreshold	Minimum allowed pattern contrast in the graycode images (for 3D reconstruction);	Only pixels whose gray value difference between the bright and dark images is equal to or greater than the limit value set are used for the calculation.
AmplitudeThreshold	Minimum allowed pattern contrast in the sinus images (for 3D reconstruction);	Only pixels whose amplitude value is greater than this threshold value are used to calculate the result. This allows you to exclude unwanted pixels with a low degree of reflection (e.g., outside the measured object or near the edges).
<i>MaximumPhaseGradientEnable</i>	Controls if threshold to sort out outliers is active.	Enables filtering of high gradient data in Z.
<i>MaximumPhaseGradient</i>	Threshold to sort out outliers in 3d point cloud.	Threshold for filtering with high gradient in Z.
<i>MinimumIntensityThreshold</i>	Threshold to sort out underdriven pixels.	Threshold for filtering of underexposed pixels.
<i>MaximumIntensityThreshold</i>	Threshold to sort out overdriven pixels.	Threshold for filtering of overexposed pixels.
PatternType	Selects the type of pattern projection.	Provides pre-defined options for setting the number of sine patterns which are used for one measurement: - HighSpeed: 4 - Balanced: 6 - HighPrecision: 12
<i>PerformanceMode</i>	Boosts data processing speed while increasing internal temperature of sensor.	Significantly increases the data processing speed at the expense of the sensor's internal temperature. - On: The measurement speed will increase depending on the sensor settings by up to 85%. - Off: The sensor's internal temperature can decrease by up to approx. 5 °C during continuous operation. The sensor can thus be operated in correspondingly higher ambient temperatures.
Scan3dControl		
Scan3dCoordinateSelector	Selects the individual coordinates in the vectors for 3D information/transformation.	Serves as a switch for the selected 3D coordinate.
Scan3dCoordinateScale [Scan3dExtractionSelector] [Scan3dCoordinateSelector]	Scale factor when transforming a pixel from relative coordinates to world coordinates.	Defines the distance between points in the measuring field [mm] in x and y direction. If the Mono16 format is used, scaling can be defined additionally for the z coordinate.
Scan3dCoordinateOffset [Scan3dExtractionSelector] [Scan3dCoordinateSelector]	Offset when transforming a pixel from relative coordinates to world coordinates.	Defines the offset of the point cloud in x and y direction [mm]. If the Mono16 format is used, the offset can be defined additionally for the z coordinate. The formula below can be used to transform the x and y indices into real world coordinates: $\text{Coord_real} = \text{Scan3dCoordinateOffset}[\text{Scan3dCoordinateSelector}] + \text{index} * \text{Scan3dCoordinateScale}[\text{Scan3dCoordinateSelector}]$
Scan3dExtractionMethod [Scan3dExtractionSelector]	Selects the method for extracting 3D from the input sensor data.	Defines the measuring mode: - Standard: Default measuring mode - EnhancedSNR: 3D calculation with double point density
Scan3dInvalidDataFlag [Scan3dExtractionSelector] [Scan3dCoordinateSelector]	Enables the definition of a non-valid flag value in the data stream.	Indicates whether the scan3dInvalidDataValue parameter can be used to identify invalid points. The value is "true" if no mask is transmitted.
Scan3dInvalidDataValue [Scan3dExtractionSelector] [Scan3dCoordinateSelector]	Value which identifies a non-valid pixel if Scan3dInvalidDataFlag is enabled.	If no mask is transmitted, this value defines the invalid points in the 3D data.

Advanced3dControl		
MaximumDeviation	Set the maximum deviation of a calculated 3d point based on the input data	Sets the value for the maximum deviation of a calculated 3D point based on the starting value (point cloud by gray code).
SearchStep	Search step in Millimeter	Sets the step width for searching the Z range.
ErroneousPoints	Defines the handling of an erroneous calculated 3d point (e.g. > MaximumDeviation)	Defines how incorrect 3D points are handled, e.g., when the maximum deviation is exceeded (see SearchStep). Erase - point is deleted and not output StartValue - start value from gray code calculation is used
LowerLimitZ	Lower limit of the measurement range (z axis)	Sets the lower limit of the measuring range on the Z axis. [mm]
UpperLimitZ	Upper limit of the measurement range (z axis)	Sets the upper limit of the measuring range on the Z axis. [mm]
LightControl		
LightBrightness	Set the brightness of the lighting output in percent.	Sets the brightness of the LED in the projector. Note: In principle, the exposure time should first be reduced as much as possible if there is overexposure.

Event Control		
EventFrameTriggerData	Category that contains all the data features related to the FrameTrigger Event.	This event is triggered when a trigger has been initiated.
EventFrameTrigger	Returns the unique Identifier of the FrameTrigger type of Event.	This event is triggered when a trigger has been initiated.
EventFrameTriggerMissedData	Category that contains all the data features related to the FrameTriggerMissed Event.	This event is triggered when a measurement is triggered although the most recent measurement has not yet been completed.
EventFrameTriggerMissed	Returns the unique Identifier of the FrameTriggerMissed type of Event.	This event is triggered when a measurement is triggered although the most recent measurement has not yet been completed.
EventExposureEndData	Category that contains all the data features related to the ExposureEnd Event.	This event is triggered when image acquisition for a measurement has been completed and calculation of the 3D results is started. The sensor or measuring object can now be moved to the next measuring position.
EventExposureEnd	Returns the unique identifier of the ExposureEnd type of Event.	This event is triggered when image acquisition for a measurement has been completed and calculation of the 3D results is started. The sensor or measuring object can now be moved to the next measuring position.
EventFrameStartData	Category that contains all the data features related to the FrameStart Event.	This event is triggered when the measurement is started.
EventFrameStart	Returns the unique identifier of the FrameStart type of Event.	This event is triggered when the measurement is started.
EventFrameEndData	Category that contains all the data features related to the FrameEnd Event.	This event is triggered when the measurement is completed.
EventFrameEnd	Returns the unique identifier of the FrameEnd type of Event.	This event is triggered when the measurement is completed.
EventWarningData	Category that contains all the data features related to the Warning Event.	This event is triggered when a warning occurs during the measurement.
EventWarning	Returns the unique identifier of the Warning type of Event.	This event is triggered when a warning occurs during the measurement.
EventWarningCode	Returns an warning code for the warning(s) that happened.	This parameter returns the warning type for a warning. The following warning codes are possible: - 1: Warning: Device temperature is becoming critical.
EventWarningMessage	Returns a detailed message for the warning.	In addition to the warning, an additional description of the warning is returned if necessary.
EventErrorData	Category that contains all the data features related to the Error Event.	This event is triggered when an error occurs during the measurement.
EventError	Returns the unique identifier of the Error type of Event.	This event is triggered when an error occurs during the measurement.
EventErrorCode	Returns an error code for the error(s) that happened.	This parameter returns the defect type for a measuring error. The following error codes are possible: - 1: Error Sensor Hardware: An error occurred in a hardware component in the sensor. Contact Micro-Epsilon. - 2: Error Sensor Acquisition: An error occurred during data acquisition in the sensor. Contact Micro-Epsilon. - 3: Error 3D Reconstruction: The 3D reconstruction could not be calculated. - 9: Error Critical Temperature: As temperatures are too high, further measurements are prevented.
EventErrorMessage	Returns a detailed message for the error.	In addition to the error type, an additional description of the measuring error is returned if necessary.

User Set Control		
UserSetSelector	Selects the feature User Set to load, save or configure. Default = factory settings	Selects the user settings function for loading, saving or configuring. Here, Default means default settings.
UserSetLoad[UserSetSelector]	Loads the User Set specified by UserSetSelector to the device and makes it active.	Loads the user setting specified by "UserSetSelector" into the sensor and enables it.
UserSetSave[UserSetSelector]	Save the User Set specified by UserSetSelector to the non-volatile memory of the device.	Saves the user setting specified by "UserSetSelector" to the sensor.
UserSetDefault	Selects the feature User Set to load and make active by default when the device is reset. Default = factory settings	Selects the user setting that is loaded and enabled by default when the sensor is reset. Here, Default means factory settings.
DigitalIO Control		
LineSelector	Selects the physical line (or pin) of the external device connector or the virtual line of the Transport Layer to configure.	Selection of the GPIO port to be configured.
LineMode[LineSelector]	Controls if the physical Line is used to Input or Output a signal.	Defines whether the selected GPIO port is an input or output.
LineInverter[LineSelector]	Controls the inversion of the signal of the selected input or output Line.	Enables inverting of the input or output signal for the selected GPIO port.
LineStatus[LineSelector]	Returns the current status of the selected input or output Line.	Queries the status of the selected GPIO port.
LineStatusAll	Returns the current status of all available Line signals at time of polling in a single bitfield.	Outputs the current status of all digital in-/outputs.
LineSource[LineSelector]	Selects which internal acquisition or I/O source signal to output on the selected Line.	Selects the internal source for the output signal of the selected GPIO port.



MICRO-EPSILON MESSTECHNIK GmbH & Co. KG
Koenigbacher Str. 15 · 94496 Ortenburg / Germany
Tel. +49 (0) 8542 / 168-0 · Fax +49 (0) 8542 / 168-90
info@micro-epsilon.com · www.micro-epsilon.com
Your local contact: www.micro-epsilon.com/contact/worldwide/

X9751423-A022031MSC
© MICRO-EPSILON MESSTECHNIK